



Minipack-torre S.p.A.
Via Provinciale, 54 - 24044 Dalmine (BG) - Italy
Tel. (035) 563525 – Fax (035) 564945
E-mail: info@minipack-torre.it
<http://www.minipack-torre.it>



EN INSTALLATION, OPERATION AND MAINTENANCE

mod. **RP40**

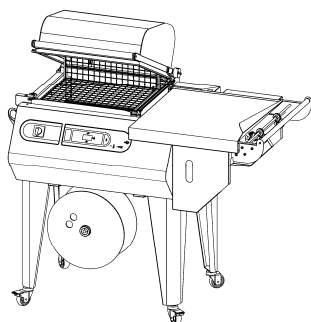

mod. **RP55**

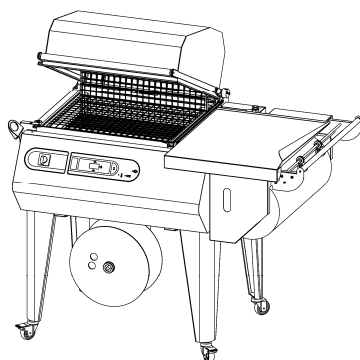

mod. **RP85**

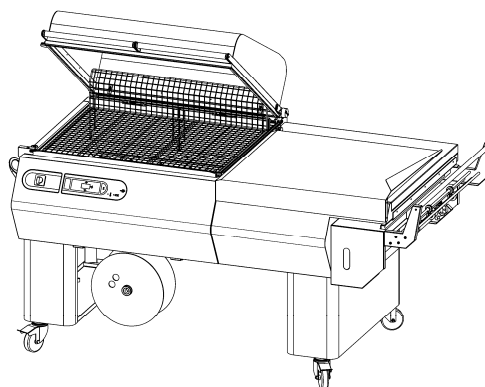

EN BEFORE USING THE MACHINE PLEASE CAREFULLY READ THE INSTRUCTIONS

EN	English	Page 14



DOC. N. FM111131
REV. 01
ED. 01.2014

TRANSLATION OF THE ORIGINAL INSTRUCTIONS





Contents

EN

Chapter 1. Description	
1.1. Preface	page 15
1.2. Machine features	page 15
1.3. Machine technical data	page 15
Chapter 2. Film features	
2.1. Films to be used	page 15
2.2. Band A calculation	page 16
Chapter 3. Machine usage conditions	
3.1. Max. weight and dimensions of the package	page 16
3.2. Items that may be packaged	page 16
3.3. Items which must not be packed	page 16
Chapter 4. Safety standards	
4.1. Warnings	page 16
4.2. Description of safety stickers	page 17
4.3. Individual protection devices	page 17
Chapter 5. Machine installation	
5.1. Transport and positioning	page 18
5.2. Environmental conditions	page 18
5.3. Electrical connections	page 18
Chapter 6. Machine adjustment and setting up	
6.1. Direction of rotation check (for mod. RP85 only)	page 19
6.2. Adjustment	page 19
6.2.1. Control panel	page 19
6.2.2. Switching the machine on	page 19
6.2.3. Program selection and variable setting	page 19
6.2.4. Alarm messages	page 21
6.3. Film reel insertion	page 21
6.4. Reticulated plate installation	page 22
6.5. Reel support and packaging plate adjustment	page 22
6.6. Making the first seal	page 22
6.7. Film binding on rewinder (if present)	page 22
6.8. Introducing the object to be packaged	page 22
6.9. Packaging	page 23
Chapter 7. Ordinary maintenance	
7.1. Instructions for ordinary maintenance work	page 23
7.2. Sealing blade cleaning	page 23
7.3. Plastic film and other scrap removal	page 23
7.4. Machine cleaning	page 23
7.5. Coolant check (if present)	page 24
7.6. Substituting the rubber and Teflon	page 24
7.7. Changing the sealing blade	page 24
7.8. Problem solving	page 25
7.9. Disassembling, demolition and elimination of residuals	page 25
Chapter 8. Guarantee	
8.1. Certificate of guarantee	page 26
8.2. Guarantee conditions	page 26
CE declaration of conformity	page 105
Wiring diagram (see attachment)	

1.1. Preface

This manual has been drawn up in compliance with the UNI10893 standard dated July 2000. It is meant for all users in order to enable them to use the machine correctly. Keep it in a place which can be easily accessed in the proximity of the machine and which is known to all users. This manual is an integral part of the machine for safety reasons. We wish to specify the symbols in use here below in order to improve understanding of them.

	ATTENTION: Accident prevention rules for the operator. This warning indicates the presence of dangers which can injure the person operating on the machine.
	ATTENTION: Hot parts. Shows the danger of burning, thus involving the risk of a serious accident for the exposed person.
	ATTENTION: Don't touch!
	WARNING: It indicates the possibility of damaging the machine and/or its components.

All reproduction rights of this manual are reserved to the manufacturer. Partial or complete reproduction is forbidden as provided by the law. Descriptions and pictures provided in this manual are not binding. Therefore the manufacturer, reserves the right to make any change considered necessary. This manual cannot be transferred for viewing to third parties without authorisation in writing from the manufacturing company.

1.2. Machine features

You have bought a machine with outstanding features and performance and we thank you very much for choosing it. The system is unique and has achieved worldwide success with more than 200000 units operating in the packaging and wrapping sector. The technological concept of its design, as well as the components and materials used in the manufacturing and testing process are the best assurance of proper operation and lasting reliability. Thanks to its particular operating circuit, it can be used both as a sealing and shrinking machine or as a sealing machine only. In the latter case it is possible to pack the object in a soft bag without shrink-wrapping.

1.3. Machine technical data

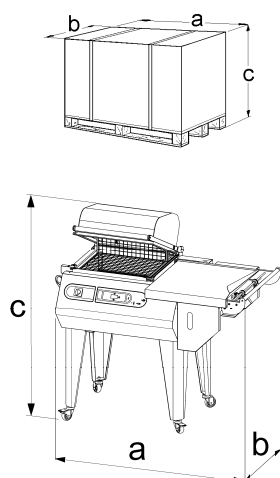

	RP40	RP55	RP85
Width "a"	1330mm	1330mm	2180mm
Length "b"	1080mm	1080mm	1040mm
Height "c"	880mm	880mm	1430mm
Weight	114Kg	123Kg	264Kg

	RP40	RP55	RP85
Width "a"	1160mm	1260mm	1950mm
Length "b"	700mm	810mm	1000mm
Height "c" (hood closed)	1120mm	1165mm	1180mm
Height "c" (hood open)	1220mm	1310mm	1480mm
Weight	90Kg	99Kg	212Kg
Maximum production	300 packs/hour	300 packs/hour	300 packs/hour

Chapter 2. Film features

2.1. Films to be used

The machine can work with all heat-shrink and non-heat-shrink films, from 15 to 50 microns in thickness, of a technical and food type. To guarantee the best results, use the films marketed by us.

The special features of our films, with regard both to compliance with laws in force and to excellent machine performance.

RP40	A = 500mm MAX	D = 250mm MAX	d = 77mm
RP55	A = 600mm MAX	D = 250mm MAX	d = 77mm
RP85	A = 800mm MAX	D = 300mm MAX	d = 77mm

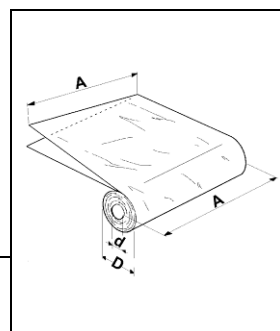

	Consult the data and safety sheets of the films in use and observe the corresponding instructions!
---	---

2.2. Band A calculation

Band A = b + c + 100mm

By band "A" we mean the width that the film must have to package the product.

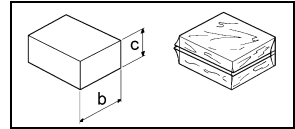

Chapter 3. Machine usage conditions

3.1. Max. weight and dimensions of the package

RP40	a = 400mm	b = 250mm	c = 160mm	Weight = 10Kg
RP55	a = 500mm	b = 380mm	c = 200mm	Weight = 15Kg
RP85	a = 800mm	b = 500mm	c = 200mm	Weight = 18Kg

Note: measurements shown refer to the maximum for the single dimension.
Refer to chapter 2.2. to get max. dimension of pack (b x c); the addition of (b + c) is equal to film roll width minus 100mm.

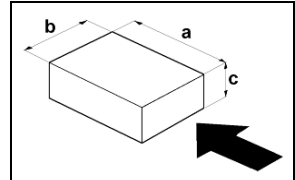

3.2. Items that may be packaged

These machines are capable of packing a wide range of completely different products. They are used successfully in the following sectors: food, marketing, graphics and mailing, large distribution, industry, fabrics.

3.3. Items which must not be packed

The products listed below must absolutely not be wrapped to avoid permanent damage to the machine and serious injuries to the operator:

	<ul style="list-style-type: none"> <input type="checkbox"/> Wet and unstable products <input type="checkbox"/> Liquids of any kind and density in fragile containers <input type="checkbox"/> Flammable and explosive materials <input type="checkbox"/> Pressurised gas cylinder of any kind <input type="checkbox"/> Loose and volatile powders <input type="checkbox"/> Bulk materials with grain size smaller than the holes of the reticulated plate <input type="checkbox"/> Any materials and products not listed but which might harm operator and damage the machine.
--	---

Chapter 4. Safety standards

4.1. Warnings

It is extremely important to read this entire chapter as it contains important information regarding risks that personnel are subject to in the event of incorrect use of the machine. These basic standards must be observed as well as specific standards applicable in the country of installation.

- The machine must be installed by trained and authorised technicians.
- This machine is not intended for use by persons (including children) with reduced physical, sensory or mental capabilities, or lack experience and knowledge, unless they have been given supervision or instruction concerning use of the machine by a person responsible for their safety.
- Children should be supervised to ensure that they do not play with the machine.
- Never use the machine for purposes other than as specified in the sales contract.
- Never allow unauthorised personnel to perform repairs or other operations on the machinery.
- The operator must be familiar with all warnings related to the tasks in hand and always be informed by the head of the site regarding risks.
- Ensure that all clothing is tight fitting, with particular reference to cuffs or other loose clothing.
- Ensure that all operating areas and transit zones are kept clear, clean and adequately lit at all times.
- Eliminate all safety hazard conditions before using the machine and always notify the head personnel of any malfunction.
- Never use the machine in the event of fault.
- Never tamper with safety devices or circuits.
- Never perform modifications on the machine without prior authorisation from the manufacturer.
- If the supply cord is damaged, it must be replaced by the manufacturer, its service agent or similarly qualified persons in order to avoid a hazard.

- The electrical enclosure must remain closed during operation.
- Smoking is forbidden while the machine is operating!
- Never performs maintenance and/or adjustments to the machine during operation. Guards may only be disassembled by suitably trained and qualified maintenance engineers.
- Never operate the machine without all guards fitted. Ensure correct position of all guards before resuming normal operation.
- If it is necessary to leave the machine unattended, switch it off by turning the main switch to the “0” (OFF) position!
- The manufacturer declines all liability for damage or phisical injury caused by failure to observe safety standards.

THE MACHINE CAN NOT BE USED BY UNTRAINED PERSONNEL!

 **During work pay attention to all hot parts of the machine. The temperature they can reach is so high that it can cause burns.**

- ❑ Do not touch the sealing blade (13) soon after sealing by reaching beyond the safety guard. Danger of burns due to residual heat on the sealing blade (13)
- ❑ Do not keep on sealing if the sealing blade breaks (13). Replace it at once
- ❑ Do not touch the chamber closing flap (16) during warm-up. Danger of burns
- ❑ Do not touch the fan while moving or using the machine without the reticulated plate (17)
- ❑ Make sure the film reel is properly lodged in is place (14)
- ❑ When the machine is not in use, leave the upper hood (18) open.
- ❑ The wheels (19) must be used only for moving the unit short distances across smooth, horizontal floors.

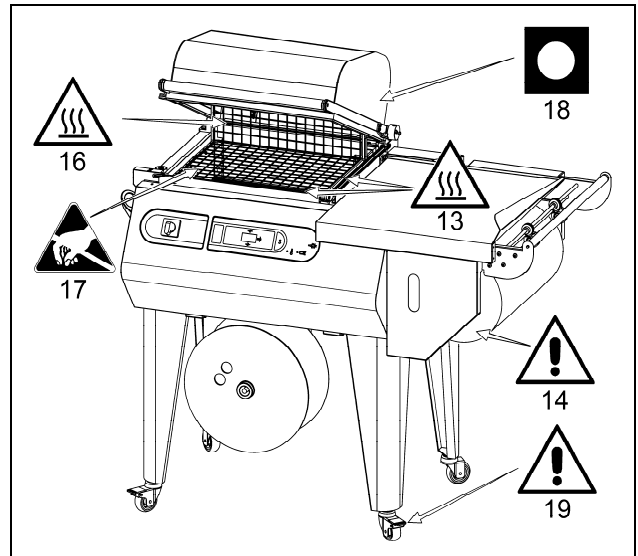

4.2. Description of safety stickers

The following safety stickers feature on the machine:

	<ul style="list-style-type: none"> ▪ On machine front panel. <p>Danger of electrocution! Risk due to presence of electrical power in electrical system inside front panel. When the panel is opened, the machine must be switched off and the plug must be pulled from the socket of the main circuit.</p> <p>While the machine is running, the front panel must be mounted properly.</p>
	<ul style="list-style-type: none"> ▪ On the guard in front of the sealing blade. ▪ On the protection panel of the heat diaphragm positioned behind the reticulated plate. <p>ATTENTION! Hot members. It shows the danger of burning, thus involving the risk of a serious accident for the exposed person.</p>

4.3. Individual protection devices

	Wear safety shoes that protect feet from impacts, crushing and compression while moving or handling the machine.
	Wear safety gloves that protect the hands from crushing and mechanical hazards and while moving or handling the machine.
	Wear safety gloves that protect the hands against cutting risks while changing the sealing blade.
	Wear safety gloves that protect the hands against the specific risks associated with the materials to be packed (mechanical, chemical) and against coming into contact with the high temperatures present on the seals and/or sealing blade (up to 100°C).
	Wear safety gloves that prevent the hands from coming into contact with foodstuffs when packaging them.

5.1. Transport and positioning



- Handle with great care during transport and positioning!
- Before any movement, make sure that the lifting means is suitable for the load to be lifted!

mod. RP40 – RP55

- ❑ Cut the strap with scissors make sure you protect your eyes by wearing glasses and withdraw the cardboard. Remove the screws and any plate intended to fasten the machine to the pallet.

If you have purchased the legs:

- ❑ Remove the box containing the legs.
- ❑ Raise the machine using a fork lift and fit the 4 legs using the screws provided.
- ❑ Cut the strap to release the upper hood.

If you have purchased the waste rewriter:

Unpack the waste rewriter and position it as indicated in the instructions provided.

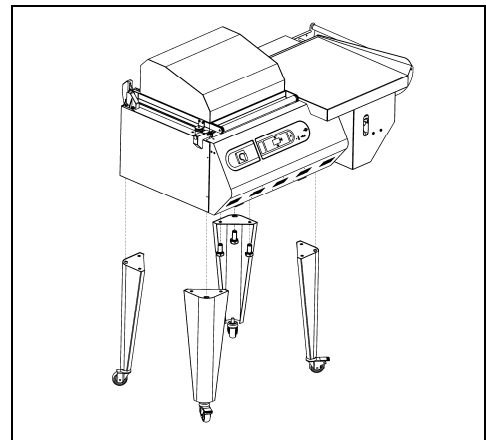

mod. RP85

- ❑ Cut the strap with scissors make sure you protect your eyes by wearing glasses and withdraw the cardboard. Remove the screws and any plate intended to fasten the machine to the pallet.
- ❑ Lift the machine by means of a fork lift truck and place it on the floor.
- ❑ Cut the strap to release the upper hood.

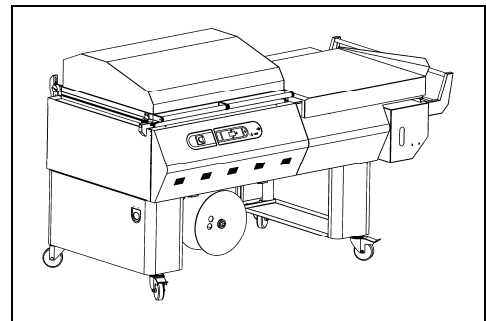

5.2. Environmental conditions

- ❑ Place the machine level on the floor in a suitable environment free from humidity, gases, explosives, combustible materials. The machine may only be installed on smooth, flat non-inflammable surfaces.
- ❑ Leave a minimum space of 0,5m around the machine so that not to obstruct air inlets
- ❑ Once the correct position is achieved, lock the machine by means of the wheel brakes.

Working environment conditions:

- ❑ Temperature from + 5°C to + 40°C
- ❑ Relative humidity from 30% to 90%, without condensation.

The lighting of the operation room shall comply with the laws in force in the country where the machine is installed. However, it shall be uniform and allow good visibility in order to safeguard the operator's safety and health.

MACHINE PROTECTION FACTOR = IP20

THE AIRBORNE NOISE MADE BY THE MACHINE IS LOWER THAN 70 dB(A)

5.3. Electrical connections

Voltage (V): see data on plate

Frequency (Hz): see data on plate

Maximum absorbed power (W): see data on plate

Maximum absorbed current (A): see data on plate

Note: when contacting the Manufacturer, always indicate the model and the serial number specified on the plate on the rear part of the machine.

MINIPACK-TORRE S.p.A. 24044 DALMINE (BG) - ITALY w w w . m i n i p a c k - t o r r e . i t			
V~	Hz	W max	A max
MOD. ANNO MATR.			
MADE IN ITALY			



OBSERVE HEALTH AND SAFETY REGULATIONS!

If the machine is not equipped with the power supply plug, use a plug that is suitable for the voltage and amperage values described by the rating plate and that can comply with the rules in force in the installation country.

GROUNDING OF THE UNIT IS OBLIGATORY!

Before making electrical connections, make sure the mains voltage matches the one on the plate on machine rear and that the ground contact complies with the safety rules in force.

In case of doubts about the mains voltage, contact the local power supply company.

Insert the plug on the cable from machine electrical cabinet in a mains power supply socket that can be reached easily by the operator.

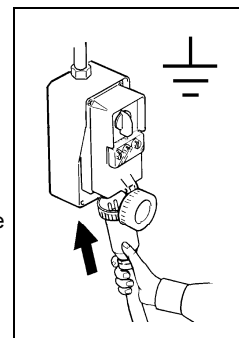

6.1. Direction of rotation check (for mod. RP85 only)



Before starting the machine operation check the right direction of rotation following these instructions:

Rotate the main switch (1) on 1-position.
 Lower down the upper hood and execute a work cycle by making sure that the direction of rotation of the fans will correspond to figure.
 If it rotates in the opposite direction to this, it is necessary to shutdown the machine, remove the power supply plug and invert two of the three-phases of the plug.

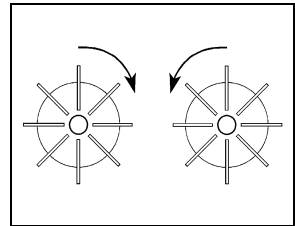

Note: The control of direction of rotation should be carried out each time you change the electrical plug.

6.2. Adjustment

6.2.1. Control panel

The machine is fitted with a control panel, from which all programming and operation functions can be set.

- 1 Main switch
- 2 Button "DECREASE". Reduces set function values
- 3 Button "INCREASE". Increases set function values
- A Temperature warning light
- B Shrinking warning light
- C Sealing warning light
- P Cycle counter selection button
- D Display. Displays selected functions and relative settings
- S Programme and variable selection button

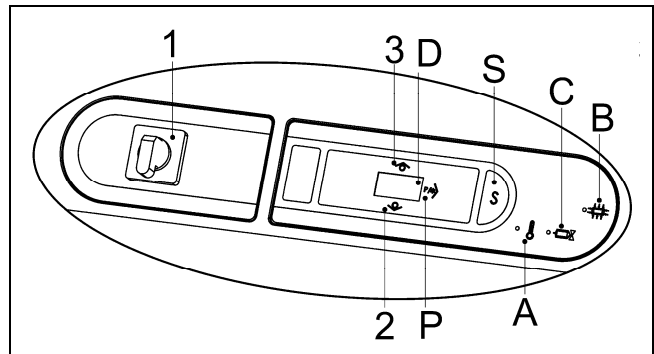

6.2.2. Switching the machine on

Turn the main switch (1) into pos. 1.
 The display (D) turns on and the number of the currently selected program will appear.
 Switching the machine on (with programs P02+P10) powers the shrinking heat element which begins to heat up.
 Before using the machine, wait until the adjusting temperature is reached. This is signalled by the extinction of the warning light (A).

6.2.3. Program selection and variable setting

The machine is equipped with 10 selectable programs (P01+P10).
 Push buttons (2) and (3) to select the number of the program.

Program P01

This program is for film sealing only.
 The film melts due to the heat of the sealing blade. The pressure between the sealing blade and the upper contrast lined in Teflon separates the 2 edges of the film.
The product to be packed is enclosed in a slack bag.

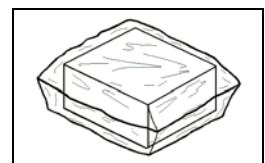

Program P02+P10

This program seals and shrinks film simultaneously.
 Shrinking is produced by the forced circulation of hot air around the the package. Air is heated by passing through a heat element (heat diaphragm).
The product to be packed is enclosed in a bag which perfectly adheres to its shape.

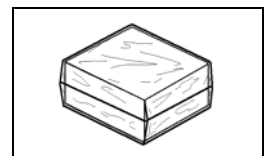

The number of settable variables will depend upon the programme number (see the following table).
 The programmes P02+P10 must be programmed in the following order (only the sealing time can be set up for programme 01):

1. Sealing time
2. Fan delay time after sealing
3. Shrinking time
4. Heat chamber temperature

Through button (S) it is possible to look through the variables of the selected program, while through buttons (2) and (3) the memorized values can be modified. These buttons (2) and (3) act by one digit at a time, but if they are held down for more than a second, the value will rapidly increase or decrease.

To validate modifications, press button (S) until the number of the program appears on the display.

The fan delay time after sealing can be modified; there is not a LED indicating this variable which is shown with an “r” on the left display, whereas the two remaining digits will indicate the set up time.

At the end of all variables to be adjusted, the display will show the code of the program just chosen (for example P01).

Note: If the hood is closed during the programming phase, the machine will not work.

Once all adjustments have been made, the machine is ready to start working.

TABLE OF PARAMETERS ACCORDING TO PROGRAMMES		
Variable	P01 (sealing only)	P02, 03, 04, 05, 06, 07, 08, 09, 10 (sealing and shrinking)
Sealing time (values expressed in seconds)	Min. = 0,0 Max. = 3,0 Default = 1,3	Min. = 0,0 Max. = 3,0 Default = 1,3
Fan delay time after sealing (values expressed in seconds)	not settable	Min. = 0,0 Max. = 1,0 Default = 0,0
Shrinking time (values expressed in seconds)	not settable	Min. = 0,0 Max. = 10,0 Default = 2,5
Heat chamber temperature the indicated value will correspond to: 0 = 0° (the heating element is switched off) 1 ... 150 = 100° ... 398°C (2°C each point)	not settable	Min. = 0 Max. = 150 Default = 120

CYCLE COUNTER

When the machine is in the PROGRAMS SELECTION mode, the display will show the programme that is being run (e.g. “P01”).

In this mode, press button (P) to activate the “cycle counter” function”.

The display indicates the number of cycles since the machine was switched on.

Then, press and hold buttons (2), (3) and (S) simultaneously for 3 seconds to activate the “totalizer” function.

The display indicates a figure corresponding to the total number of cycles performed by the machine, expressed in thousands.

Starting from the right, the numbers that appear on the display indicate:

- 1st number = thousands of cycles
- 2nd number = tens of thousands of cycles
- 3rd number = hundreds of thousands of cycles

Press button (2) again and the display indicates a number corresponding to the units.

The display indicates a figure corresponding to the total number of cycles performed by the machine, expressed in units.

Starting from the right, the numbers that appear on the display indicate:

- 1st number = single cycles
- 2nd number = tens of cycles
- 3rd number = hundreds of cycles

Press button (2) again to return to the “cycle counter” function

Finally, press button (P) to return to normal operation (the display shows the current programme).

APPROXIMATE TABLE OF MACHINE CICLE ADJUSTEMENT		
Shrinking time	Pause time	Heat chamber temperature (value indicated on the display)
6”	6”	
5”	7”	
4”	8”	
3”	9”	
2”	10”	

6.2.4. Alarm messages

The electronic board detects series of alarms that are indicated on the display (D) by the following messages:

- A:** **The machine power voltage is below (~ 10%) that provided by the network.**
The control board must be replaced.
Contact the after-sales technical assistance.
- AL1:** **Limit switch B1 closed when the machine is switched on.**
Possible causes are:
 Machine on and hood down. Lift the hood.
 Limit switch B1 faulty. Repair or replace the limit switch.
The machine will not execute the cycle in both cases. It is necessary to open the limit switch contact to cancel signalling.
The alarm will disappear as soon as the contact is opened.
- AL2:** **Temperature not reached.**
The working temperature was not reached in the pre-set time (15 min.).
Check that the thermocouple is positioned correctly. Check the heating element.
To reset the alarm, switch the machine off and on again.
- AL3:** **Maximum temperature exceeded or thermocouple tripped.**
 The element has exceeded the maximum permissible temperature or the thermocouple has tripped.
Check the thermocouple.
To reset the alarm, switch the machine off and on again.
 Should the alarm appear again, the flat cable of the membrane head may be faulty.
Check the cable is intact. Replace the membrane head if the cable is faulty.
- AL4:** **Thermocouple polarity inverted.**
Check the thermocouple connections.
To reset the alarm, switch the machine off and on again.
- AL5:** **Sealing blade safety device.**
To reset the alarm, switch the machine off and on again.
If the machine operates normally when it restarts it means that an incorrect operation has been carried out (e.g. two sealing operations in a very short space of time).
If the alarm recurs it means that there is a fault on the power board.
Contact the technical assistance.
- ALL:** **Hood closed after shrinking.**
If the hood remains closed during a shrinking cycle for longer than the pre-set shrinking time, the machine continues the shrinking for a maximum of 10 seconds, after which it stops running.
To reset the alarm, simply open the hood.
- EEE:** **Machine lock.**
Contact the technical assistance.
- FF1:** **Memory.**
- FF2:** To reset the alarm, switch the machine off and on again while pressing the buttons (2) and (3) for 3 seconds.
- E_COM:** Electrical interference has rendered communication between the boards incomprehensible.
To reset the alarm, switch the machine off and on again.

6.3. Film reel insertion

- Insert the reel of film on the roller (5) and lock it with the centring cones (6)
- Position the roller on the film reel support
- Feed the film around the return roller (7)
- Run through the micropunches (8)
- Run the film over the film drive roller (9)
- Feed the film around the return roller (10)
- Run the film lower layer under the packaging plate (11)
- Run the film upper layer over the packaging plate (11).

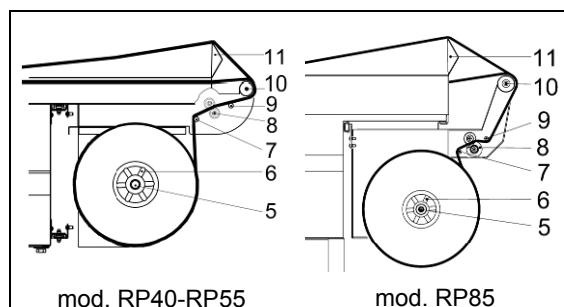

6.4. Reticulated plate installation

The reticulated plate (12) can be placed according to the height of the product to pack.

For a proper packaging the reticulated plate must be positioned so that film sealing is at the half of the package height.

To position it follow this procedure:

- Pull the reticulated plate in direction of the arrows
- Remove it from the stops
- Position the plate on the stops at the required height.

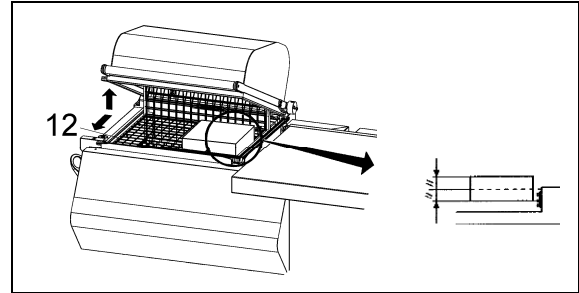

6.5. Reel support and packaging plate adjustment

The reel support (4) and the packaging plate (11) must be adjusted according to the width of the article to be packaged, leaving a space of about 1-2 cm between the article and the welding edge.

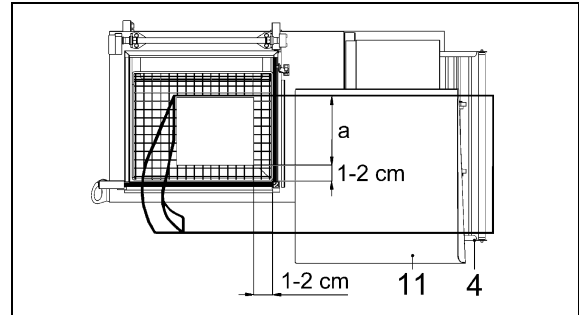

6.6. Making the first seal

Place film as shown in the picture to carry out the 1st seal. Lower the handle of the cover with your left hand and make a pressure of 10-15 Kg.

Machine will automatically operate and the first seal will be carried out on the side of the film.

With the right hand detach the film from the sealing blade.

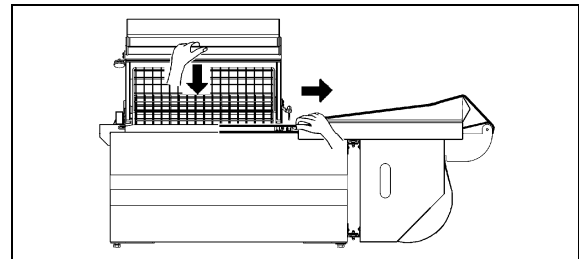

6.7. Film binding on rewinder (if present)

Carry out a number of cycles sufficient to make a strip of scrap film.

Guide this film strip around the transmission rollers (26) and (27) and the control roller (28) and bind it to the rewinder (29).

The machine is now ready to start packaging.

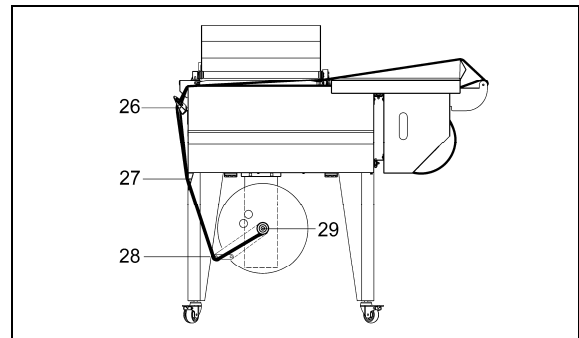

6.8. Introducing the object to be packaged

With the left hand slide on the packaging plate the quantity of film necessary to contain the product to be packed.

Introduce the product into the bag using the right hand and make it slide to the left until it is laid on the screen leaving a little space of about 1-2 cm to allow the passage of air for shrinkwrapping.

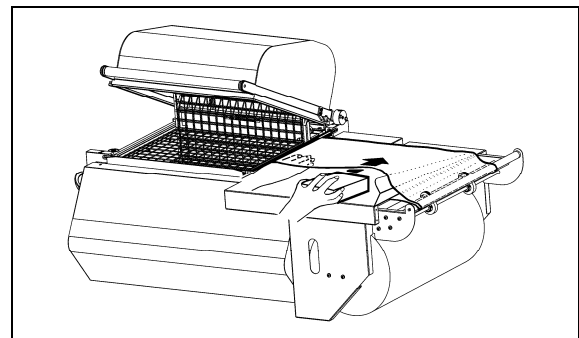

6.9. Packaging

By pushing the cover handle with a pressure of 15 Kg. the cover rests on the sealing blade; by pinching the film, it is automatically sealed on the open sides (right and front). In case you have selected the function "SEALING + SHRINKWRAPPING" (programs P02÷P10) you will see the film shrink onto the product. Slightly decrease the pressure on the cover handle to allow film detach from the sealing area on the inside. With the right and detach the film from the sealing blade towards the outside.

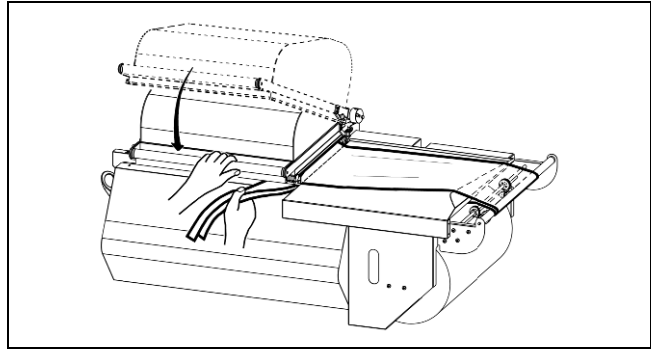

Chapter 7. Ordinary maintenance

7.1. Instructions for ordinary maintenance work

ORDINARY MAINTENANCE MUST BE CARRIED OUT BY QUALIFIED, APPROPRIATELY TRAINED STAFF.

	Before carrying out maintenance, switch the machine off with the main ON/OFF switch, disconnect it and wait for the machine to cool down!
--	--

7.2. Sealing blade cleaning

- ❑ Using a dry cloth, wipe any film residues off the sealing blade: do this at once after sealing since they are easier to remove when still warm
- ❑ For improved cleaning, regularly lubricate the sealing blade with the Teflon non-stick grease supplied with the machine.

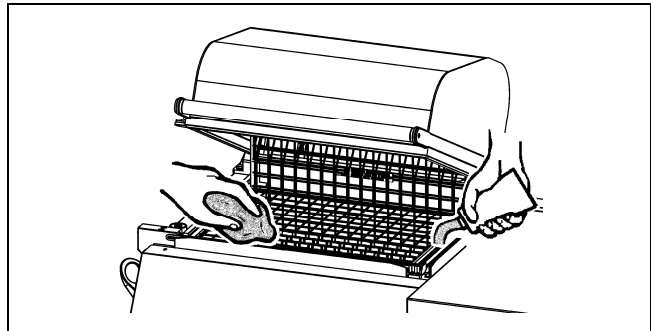

7.3. Plastic film and other scrap removal

- ❑ Wait for the machine to cool down completely before removing any scraps stuck to the hot parts of the machine (e.g. , on the flaps of the heat chamber)
- ❑ If the lower cover requires cleaning (where the fan is installed), remove the reticulated plate (17) and take out any pieces that may have fallen inside (figure A)
- ❑ When the reel on the automatic rewinder (29) is full, remove the film by unscrewing the knob (30) and taking away the disk (31) (figure B).

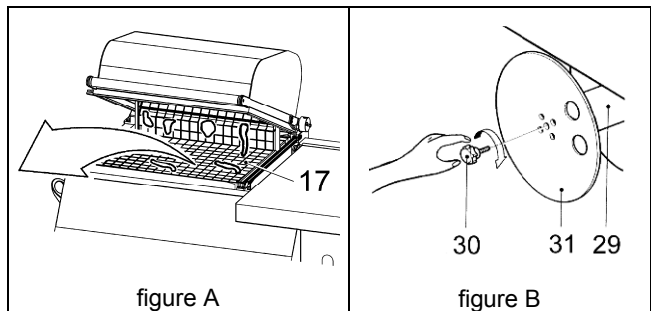

7.4. Machine cleaning



To clean the upper hood (18), clean both the outside and the inside with water and soap only (figure A). Do not use any detergents with solvents which could damage the upper hood (18) and reduce the transparency.

- ❑ Use a cloth moistened with water to clean the machine
- ❑ If the machine works in a dusty environment it is necessary to clean it more frequently inside as well as outside. We especially recommend you vacuum up the dust which settles on the interior electrical components (figure B).

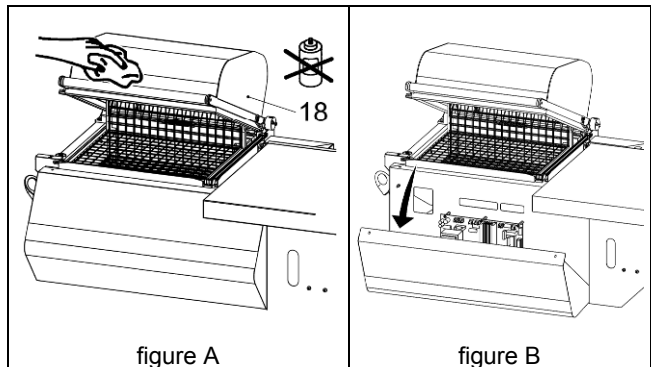

7.5. Coolant check (if present)

Check the level of the coolant every 4 months by unscrewing the rear panel (34).

Make sure the level of the liquid is not below the indicated measure. Otherwise unscrew the cap (35) and add the mixture of water and antifreeze (10%).

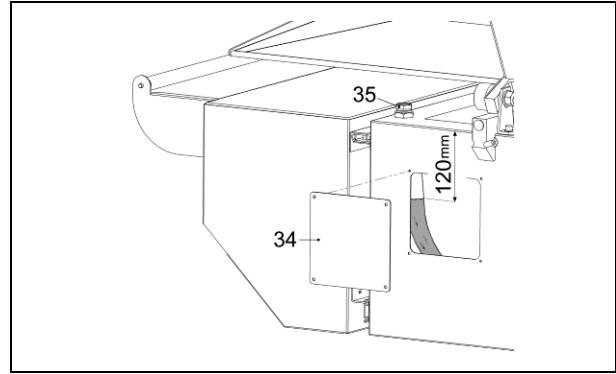

7.6. Substituting the rubber and Teflon

When the Teflon-strikers (32) are worn out, substitute them with spare parts, making sure the application is linear and even.

Before applying the Teflon self-adhesive strip clean the rubber part (33) with a detergent.

If the rubber (33) is also damaged, substitute it as follows:

- Remove the old rubber
- Clean its housing
- Insert the new rubber in a linear way
- Clean the rubber with a detergent
- Apply the self-adhesive Teflon-strip.

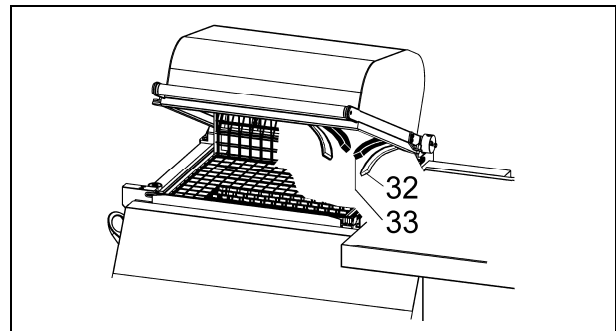

7.7. Changing the sealing blade

To substitute the sealing blade (13) follow this procedure:

- Disconnect power to the machine
- Unscrew the three screws (20), (21), (22)
- Remove the old sealing blade
- Clean the housing and if necessary substitute the insulating Teflon (23) of the central clamp
- Insert the new sealing blade starting from the central clamp and tighten the screw (21)
- Trim the new sealing blade according to the holes of the pistons (24) and (25)
- Complete the insertion of the sealing blade in the whole housing
- Push the rear piston completely (24) towards the sealing blade to make it enter the hole of the piston itself and then tighten screw (22)
- Push the front piston (25) completely towards the sealing blade to make it enter the hole of the piston itself and then tighten screw (20)
- Trim the Teflon projecting from the central clamp
- Make sure that the sealing blade is well positioned and under tension.

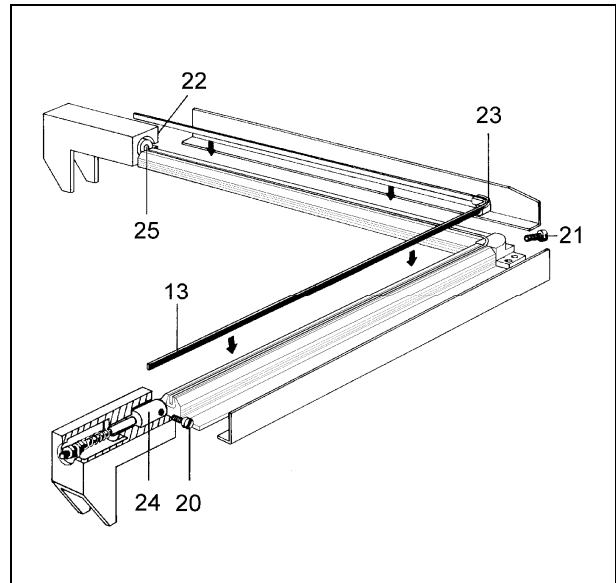

7.8. Problem solving

PROBLEM	CAUSE	SOLUTION
The machine seals but it does not shrink.	The head lung's temperature is too low	Increase the set value
	Work is being performed with program P01 (sealing only)	Change program
	The machine is in heating mode	Wait for the machine to reach the set temperature (LED "A" switch-off)
	The fan does not turn	The fan's motor is faulty. Contact the after-sales technical assistance.
	The maximum temperature of the heat lung is exceeded. The safety thermostat intervened, disconnecting the heating element.	Contact the after-sales technical assistance.
Shrinking takes place, but it is not even and complete	The film is not suitable or of scarce quality	Replace the film
	The product is too big	The product is bigger than admitted (see paragraph 3.1.)
Shrinking contains "bubbles" (the film does not adhere to the product)	The film is without micro-holes	Make the film properly slide through the micro-holes (see paragraph 6.3.)
Sealing opens during shrinking	The sealing blade is dirty or damaged	Clean the sealing blade or replace it if damaged
	Sealing time is incorrect	Adjust the sealing time
	Insufficient hood pressure	Slightly increase pressure on the hood's handle
Sealing is irregular	The film is not suitable or of scarce quality	Replace the film
Sealing does not take place	Sealing time is not enough	Increase the set value
	The sealing blade does not receive current	Repair the power supply circuit of the sealing blade. Contact the after-sales technical assistance.
	The Teflon and/or gasket of the cover are worn	Replace the Teflon and/or gasket of the cover
	The sealing blade is damaged	Replace the sealing blade
Fumes present during sealing	Sealing time is long	Decrease the set value
	Residues present on the sealing blade	Clean the sealing blade

If the machine does not work properly after the above-mentioned checks, contact the assistance service describing the detected defect.

7.9. Disassembling, demolition and elimination of residuals

	ATTENTION! All disassembling and demolition operations must be done by qualified personnel with mechanical and electrical expertise required to work in safe conditions.
---	--

Proceed as follows:

- Disconnect machine from power mains
- Disassemble components.

All wastes must be treated, eliminated or recycled according to their classification and to the procedures in force established by the laws in force in the country where the equipment has been installed.

	The symbol indicates that this product shall not be treated as household waste. By making sure that the product will be properly disposed of, you will facilitate the prevention of potential negative effects for the environment and human health, which might be otherwise caused by the improper waste treatment of this product. For more detailed information about the recycling of this product, please contact the product seller or, as an alternative, the after-sales service or the corresponding waste treatment service.
---	--

8.1. Certificate of guarantee

The guarantee runs for 12 months after the installation date under the conditions set out in the instruction manual. Fill in the card with all data requested, tear out along the perforations and send in.

8.2. Guarantee conditions

The guarantee runs for 12 months and comes into force on the installation date of the machine. The guarantee covers free replacement or repair of any parts due to defects arising from faulty material. The repairs or replacement are usually carried out at the manufacturer's premises, with transport or labour charged to the buyer. If the repair or replacement is carried out at the buyer's premises, he shall bear the travelling, transfer and labour costs. Work under guarantee can be carried out exclusively by the manufacturer or by the authorised dealer. In order to be entitled to repairs under the guarantee, the faulty part must be sent for repair or replacement to the manufacturer or his authorised dealer. The return of such repaired or replaced part will be considered fulfilment of the guarantee. The guarantee is voided:

- In case of failure to mail the CERTIFICATE OF GUARANTEE, duly filled in and signed, with in 20 days after the date of purchase
- In case of inappropriate installation, power supply, misuse and mishandling by unauthorised persons
- In case of changes made to the machine without prior agreement in writing from the manufacturer
- If the machine is no longer the property of the first buyer.

The manufacturer declines all liability for personal injury or damage in case of inappropriate installation or connection to the power mains or omission of connection to earth or in case of any mishandling of the machine. The manufacturer undertakes to carry out any variations and changes made necessary by technical and operating requirements.

**IN THE EVENT OF DISPUTES THE COURT OF BERGAMO (ITALY)
SHALL HAVE SOLE JURISDICTION.**



IT	DICHIARAZIONE CE DI CONFORMITA'	SV	ÖVERENSTÄMMELSEFÖRKLARING EC
EN	CE DECLARATION OF CONFORMITY	PT	DECLARAÇÃO CE DE CONFORMIDADE
DE	KONFORMITÄTSEKTLÄRUNG	EL	ΔΗΛΩΣΗ ΠΙΣΤΟΠΟΙΗΣΗΣ CE
FR	DECLARATION CE DE CONFORMITE'	CS	ES PROHLÁŠENÍ O SHODĚ
ES	DECLARACIÓN CE DE CONFORMIDAD	RU	ДЕКЛАРАЦИЯ СООТВЕТСТВИЯ CE

IT Noi: SV Vi:
 EN We: PT Nós:
 DE Wir: EL Εμείς:
 FR Nous: CS My:
 ES Nosotros: RU Мы:

MINIPACK-TORRE S.p.A.
Via Provinciale, 54 - 24044 - DALMINE (BG)

IT dichiariamo sotto la nostra esclusiva responsabilità che il prodotto
 EN declare under our responsibility that the product
 DE erklären unter unserer ausschließlichen Verantwortung, dass das in dieser Erklärung genannte Produkt
 FR déclarons sous notre exclusive responsabilité que le produit
 ES declaramos bajo nuestra exclusiva responsabilidad que el producto
 SV förklarar under eget ansvar, att produkten
 PT declaramos sob a nossa exclusiva responsabilidade que o produto
 EL δηλώνουμε υπεύθυνα ότι το προϊόν
 CS prohlašujeme výhradně na vlastní zodpovědnost, že produkt
 RU под нашу исключительную ответственность заявляем, что данное изделие

IT MACCHINA CONFEZIONATRICE TIPO:
 EN PACKAGING MACHINE MODEL:
 DE VERPACKUNGSMASCHINE TYP:
 FR MACHINE D'EMBALLAGE MODELE:
 ES MÁQUINA CONFECCIONADORA TIPO:
 SV PACKNINGSMASKIN TYP:
 PT MÁQUINA CONFECCIONADORA TIPO:
 EL ΜΗΧΑΝΗ ΣΥΣΚΕΥΑΣΙΑΣ ΤΥΠΟΥ:
 CS BALICI SROJ MODEL:
 RU УПАКОВОЧНАЯ МАШИНА ТИПА:

<input type="checkbox"/>	RP40	n°	/
<input type="checkbox"/>	RP55	n°	/
<input type="checkbox"/>	RP85	n°	/

IT è conforme ai requisiti essenziali di sicurezza e a tutte le disposizioni pertinenti delle direttive applicabili
 EN conforms to the essential safety requirements and all the provisions of the applicable directives
 DE entspricht den grundlegenden Sicherheitsanforderungen und allen betreffenden Bestimmungen der einschlägigen Richtlinien
 FR est conforme aux exigences essentielles de sécurité et à toutes les dispositions pertinentes des directives applicables
 ES cumple los requisitos fundamentales de seguridad y todas las normas pertinentes de las directivas aplicables
 SV uppfyller de väsentliga säkerhetskraven och relevanta bestämmelser i gällande direktiv
 PT é conforme os requisitos essenciais de segurança e a todas as disposições pertinentes das directivas aplicáveis
 EL συμμορφώνεται με τις βασικές απαιτήσεις ασφαλείας και όλες τις συναφείς διατάξεις των εφαρμοσίμων οδηγιών
 CS splňuje základní požadavky na bezpečnost a všechna příslušná ustanovení platných směrníc
 RU соответствует основным требованиям безопасности и всем соответствующим положениям в действующих директивах

2006/42/CE, 2004/108/CE, 2006/95/CE

IT E inoltre dichiariamo che sono state applicate le seguenti norme armonizzate
 EN And furthermore we declare that the following rules have been applied
 DE außerdem bestätigen wir, dass folgende harmonisierte Richtlinien angewendet wurden
 FR Nous déclarons également que les normes harmonisées suivantes ont été appliquées
 ES Además declaramos que han sido aplicadas las siguientes normas armonizadas
 SV Dessutom förklarar vi, att följande harmoniserade normer har använts
 PT E, além disso, declaramos que foram aplicadas as seguintes normas harmonizadas
 EL Επίσης δηλώνουμε ότι εφαρμόστηκαν οι εξής εναρμονισμένες προδιαγραφές
 CS A kromě toho prohlašujeme, že byly aplikované následující harmonizované normy
 RU Также мы заявляем, что были применены следующие согласованные нормативы

EN 12100:2010, EN 61000-6-3:2007, EN 61000-6-1:2007, EN 60335-1

IT Persona autorizzata a costituire il Fascicolo Tecnico: Responsabile Ufficio Tecnico
 EN Person authorised to compile the Technical File: Technical Office Manager
 DE Zur Erstellung des Technischen Merkhefts befugte Person: Verantwortlicher der Technischen Abteilung
 FR Personne autorisée à constituer le Fascicule Technique: Responsable Bureau Technique
 ES Persona autorizada a elaborar el Fascículo Técnico: Responsable del Departamento Técnico
 SV Person med behörighet att skapa den Tekniska Dokumentationen: Tekniskt ansvarig
 PT Pessoa autorizada a compilar o Processo Técnico: Responsável pelo Gabinete Técnico
 EL Άτομο εξουσιοδοτημένο να καταρτίσει το Τεχνικό Τεύχος: Υπεύθυνος Τεχνικού Γραφείου
 CS Osoba autorizovaná k vystavení Technické dokumentace: Vedoucí technického oddělení
 RU Лицо, уполномоченное для составления технического файла: начальник технического отдела

Dalmine,

Torre P.L. Fabio Emanuele

IT Consigliere Delegato SV Verkställande Direktör
 EN Managing Director PT Conselheiro Delegado
 DE Geschäftsführer EL Ο Διευθύνων Σύμβουλος
 FR Directeur Général CS Generální ředitel
 ES Consejero Delegado RU Управляющий директор



(IT) Tipo / (EN) Type
 (DE) Typ / (FR) Type
 (ES) Tipo / (SV) Typ
 (PT) Tipo / (EL) Τύπος
 (CS) Typ / (RU) Тип

(IT) Matricola n° / (EN) Serial n°
 (DE) Kennnummer / (FR) No. de série
 (ES) No.de matrícula / (SV) Registreringsnummer
 (PT) Número de série / (EL) Κωδικός
 (CS) VÝrobní číslo / (RU) Паспортный №

(IT) Collaudo / (EN) Test n°
 (DE) Abnahmeprüfung / (FR) Essai
 (ES) Ensayo / (SV) Besiktning
 (PT) Teste / (EL) Δόκιμη
 (CS) Kolaudace / (RU) Проверочные испытания

CERTIFICATO DI GARANZIA / CERTIFICATE OF GUARANTEE
 GARANTIESCHEIN / BULLETIN DE GARANTIE
 CERTIFICADO DE GARANTIA / GARANTIINTYG
 CERTIFICADO DE GARANTIA / ΠΙΣΤΟΠΟΙΗΤΙΚΟ ΕΓΓΥΗΣΗΣ
 CERTIFIKÁT ZÁRUKY / ГАРАНТИЙНЫЙ СЕРТИФИКАТ

Data e timbro rivenditore / Date and dealer's stamp
 Datum und stempel des verkaufers / Date et timbre du revendeur
 Fecha y timbre del revendedor / Datum och återförsäljarens stämpel
 Data e carimbo revendedor / Ημερομηνία και σφραγίδα εξουσιοδοτημένου πωλητή
 Datum a razítko prodejce / Дата и печать продавца

(IT) Indirizzo acquirente / (EN) Customer address
 (DE) Adresse des Abnehmers / (FR) Adresse de l'acheteur
 (ES) Dirección del comprador / (SV) Köparens adress
 (PT) Endereço comprador / (EL) Διεύθυνση αγοραστή
 (CS) Adresa zákazníka / (RU) Адрес покупателя

(IT) Data di acquisto / (EN) Purchase date
 (DE) Einkaufdatum / (FR) Date d'achat
 (ES) Fecha de compra / (SV) Inköpsdatum
 (PT) Data de compra / (EL) Ημερομηνία αγοράς
 (CS) Datum zakoupení / (RU) Дата покупки



Spett.le
minipack-torre S.p.A.

Via Provinciale, 54
24044 DALMINE (BG)
ITALY

MADE IN ITALY