



Synthesis

Spare parts catalogue

(Valid from serial number 1132 dated 09.1999

and the same for 935÷964, 985÷1004, 1030÷1039, 1044÷1053, 1074÷1083, 1104÷1123)

Warning: from serial number 935 to serial number 1131 both old style and new style heating chambers have been contemporarily manufactured.

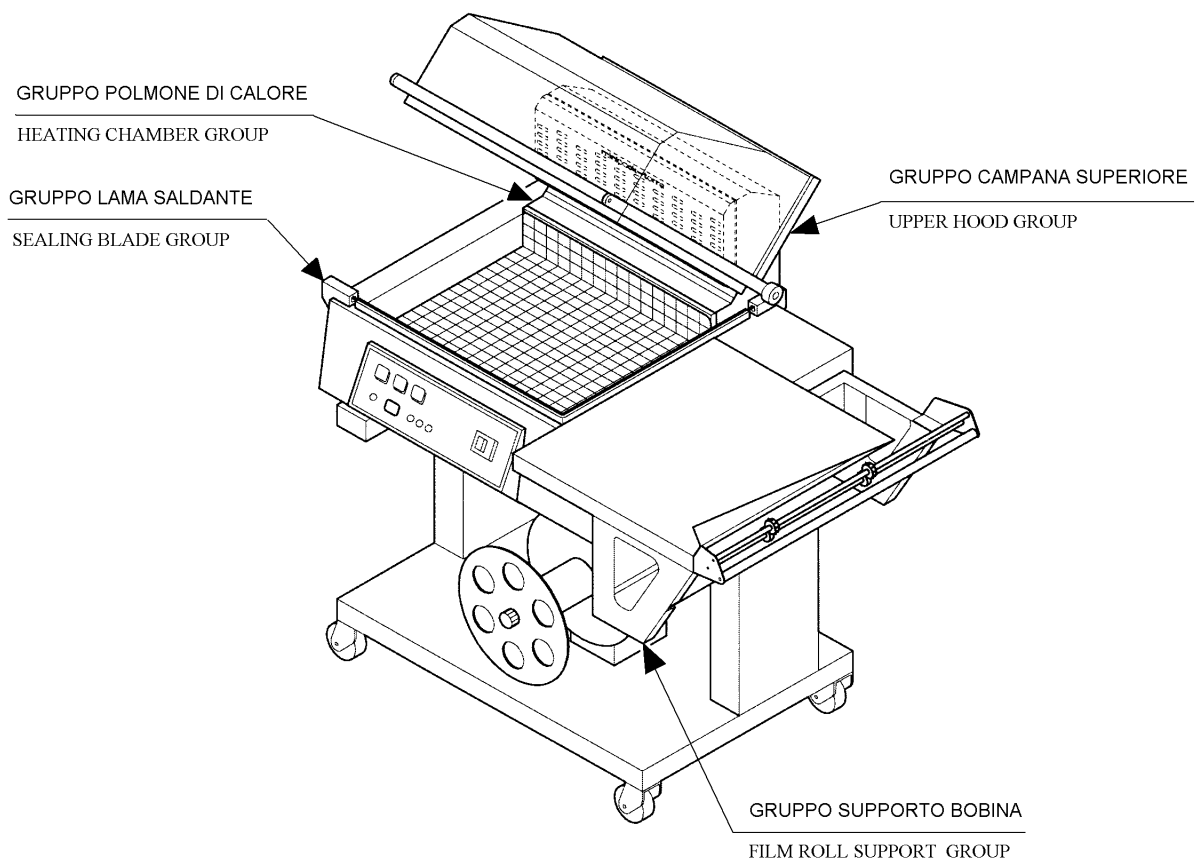

Carefully read this booklet before ordering spare parts



DOC. N. FM112008
REV. 01
Ed: 01.2000

INDEX OF SPARE PARTS GROUPS

SEALING BLADE GROUP		
S0K00301	Front clamp kit	page 01
S0K00302	Rear clamp kit	page 01
S0K00306	Blade holder central clamp kit	page 02
S0K00407	Film guide kit	page 02
S0K01112	Front and rear piston kit	page 03
S0K01301	Screened plate front support kit	page 03
S02A0306	Infill holder channel kit	page 04
S02A0310	Infill blocks kit	page 04
S02A0901	Front guard kit	page 05
S02A0902	Side guard kit	page 05

UPPER HOOD GROUP		
S0K00403	Heating chamber flap opening lever kit	page 06
S0K00406	Microswitch screw kit	page 06
S0K01001	Torsion bar blocking flange kit	page 06
S0K01002	Hood rotation right pin kit	page 07
S0K01004	Torsion bar housing kit	page 07
S0K01005	Hood rotation left pin kit	page 08
S0K01208	Electrica microswitch kit	page 08
S02A0402	Hood handle kit	page 09
S02A0404	Teflon kit	page 09
S02A0804	Lock channels kit	page 10
S02A0806	Rubber holder channels kit	page 10

FILM ROLL SUPPORT GROUP		
S0K00604	Slotted microperforator kit	page 11
S0K00605	Microperforator with needles kit	page 11
S02A0803	Film roll tube kit	page 12
S02A0807	Orange microperforator support kit	page 12
S02B0807	Grey microperforator support kit	page 12
S02I0807	Inox microperforator support kit	page 12
S02A0808	Sliding guides + corners kit	page 13
S02A0909	Coupled guides kit	page 13
PB02A083	Orange film roll support kit	page 14
PB02B083	Grey film roll support kit	page 14
PB02I082	Inox film roll support kit	page 14
PB02I083	Orange film roll support kit and inox packaging plate	page 14
PB02I183	Grey film roll support kit and inox packaging plate	page 14
PB02N080	Second film roll support kit	page 15

HEATING CHAMBER GROUP		
PB020A85	230V heating chamber kit	page 16
PB020D85	200V heating chamber kit	page 16
PB020E85	115V heating chamber kit	page 16
S02A0802	Fan + bush kit	page 17

AV020A80	230V film winder group	page 18
AV020E80	115V film winder group	page 18
CA02N002	Orange trolley	page 19
CA02N003	Grey trolley	page 19
CA02N006	Inox trolley	page 19

MACHINE DETAIL DRAWING		
SCHEME 1		page 21
SCHEME 2		page 22
SCHEME 3		page 23
SCHEME 4		page 24
SCHEME 5		page 25

WIRING DIAGRAM		page 26
-----------------------	--	---------

SEALING BLADE GROUP

GROUP CODE	GROUP DESCRIPTION		
S0K00301	Front clamp kit		
POS.	ITEMS CODE	ITEMS DESCRIPTION	Q.ty
1	FM290125	Blade tightener front support	1
2	FM850704	M3X10 PR80 screw	1
3	FM210001	Blade tightener piston	1
4	FM170101	Compression spring	1

GROUP CODE	GROUP DESCRIPTION		
S0K00302	Rear clamp kit		
POS.	ITEMS CODE	ITEMS DESCRIPTION	Q.ty
1	FM290126	Blade tightener rear support	1
2	FM850704	M3X10 PR80 screw	1
3	FM210001	Blade tightener piston	1
4	FM170101	Compression spring	1

SEALING BLADE GROUP

GROUP CODE	GROUP DESCRIPTION		
S0K00306	Blade holder central clamp kit		
POS.	ITEMS CODE	ITEMS DESCRIPTION	Q.ty
1	FM180001	Blade holder central clamp	1
2	FM850704	M3X10 PR80 screw	1
3	FM040001	Insulating strip	1

GROUP CODE	GROUP DESCRIPTION		
S0K00407	Film guide kit		
POS.	ITEMS CODE	ITEMS DESCRIPTION	Q.ty
1	FM030046	Film guide rod	1
2	FM180007	Film guide rod clamp	1
3	FM510035	Knob	1

SEALING BLADE GROUP

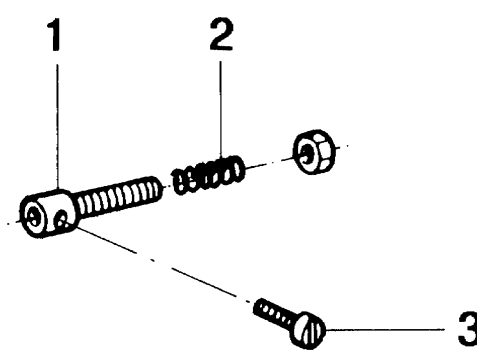
GROUP CODE	GROUP DESCRIPTION		
S0K01112	Front and rear piston kit		
			
POS.	ITEMS CODE	ITEMS DESCRIPTION	Q.ty
1	FM210001	Blade tightener clamp	1
2	FM170101	Spring	1
3	FM850704	M3X10 PR80 screw	1

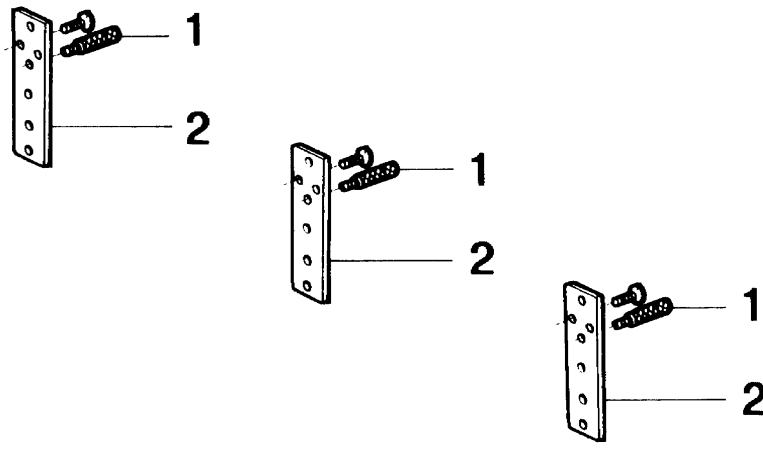
GROUP CODE	GROUP DESCRIPTION		
S0K01301	Screened plate front support kit		
			
POS.	ITEMS CODE	ITEMS DESCRIPTION	Q.ty
1	FM200002	Screened plate adjusting pin	3
2	FM290105	Screened plate front support	3

SEALING BLADE GROUP

GROUP CODE	GROUP DESCRIPTION		
S02A0306	Infill holder channel kit		
POS.	ITEMS CODE	ITEMS DESCRIPTION	Q.ty
1	FM220112	Front infill blocks channel	1
2	FM220122	Side infill blocks channel	1

GROUP CODE	GROUP DESCRIPTION		
S02A0310	Infill blocks kit		
POS.	ITEMS CODE	ITEMS DESCRIPTION	Q.ty
1	FM050112	Front blade support infill blocks	1
2	FM050113	Side blade support infill block	1

SEALING BLADE GROUP

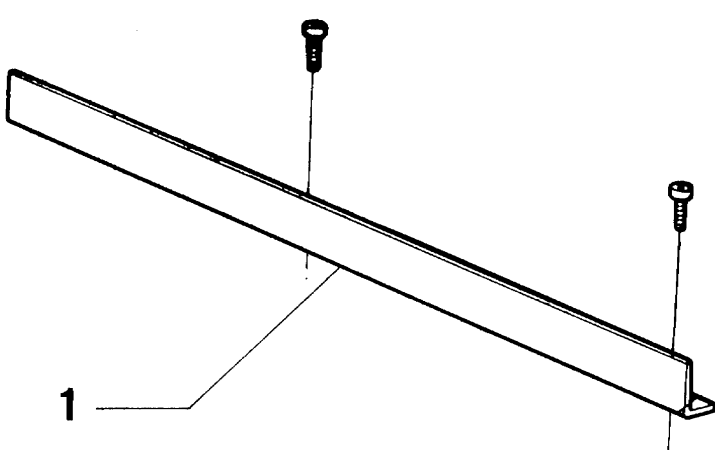
GROUP CODE	GROUP DESCRIPTION		
S02A0901	Front guard kit		
			
POS.	ITEMS CODE	ITEMS DESCRIPTION	Q.ty
1	FM220002	Front guard	1

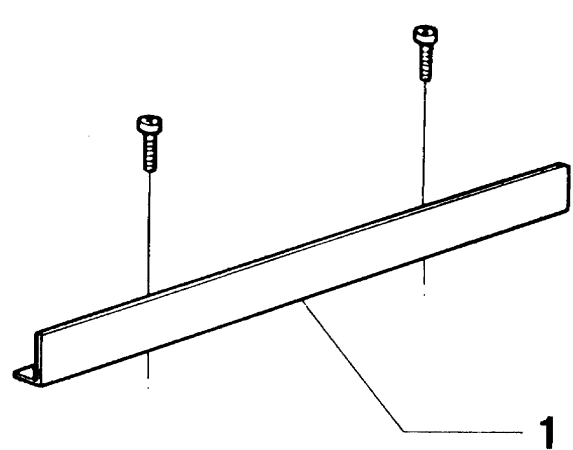
GROUP CODE	GROUP DESCRIPTION		
S02A0902	Side guard kit		
			
POS.	ITEMS CODE	ITEMS DESCRIPTION	Q.ty
1	FM220005	Side guard	1

UPPER HOOD GROUP

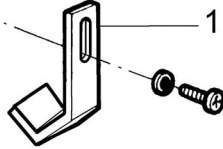
GROUP CODE	GROUP DESCRIPTION		
S0K00403	Heating chamber flap opening lever kit		
			
POS.	ITEMS CODE	ITEMS DESCRIPTION	Q.ty
1	FM280155	Flap opening lever	1

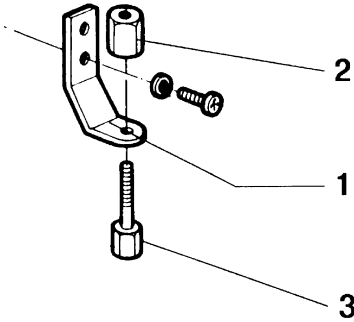
GROUP CODE	GROUP DESCRIPTION		
S0K00406	Microswitch screw kit		
			
POS.	ITEMS CODE	ITEMS DESCRIPTION	Q.ty
1	FM280001	Microswitch square holder	1
2	FM160001	Microswitch lock screw	1
3	FM160002	Microswitch screw	1

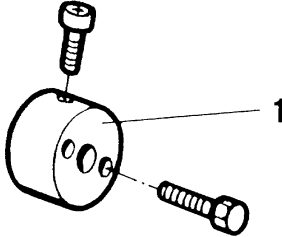
GROUP CODE	GROUP DESCRIPTION		
S0K01001	Torsion bar blocking flange kit		
			
POS.	ITEMS CODE	ITEMS DESCRIPTION	Q.ty
1	FM120002	Torsion bar flange	1

UPPER HOOD GROUP

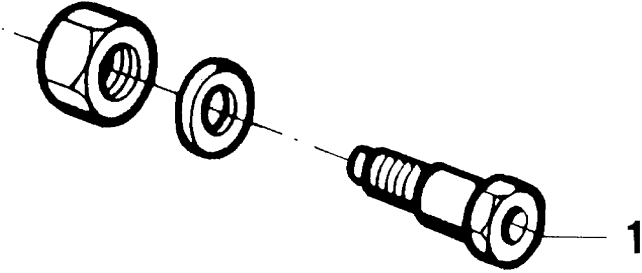
GROUP CODE	GROUP DESCRIPTION		
S0K01002	Hood rotation right pin kit		
			
POS.	ITEMS CODE	ITEMS DESCRIPTION	Q.ty
1	FM200052	Hood rotation right pin	1

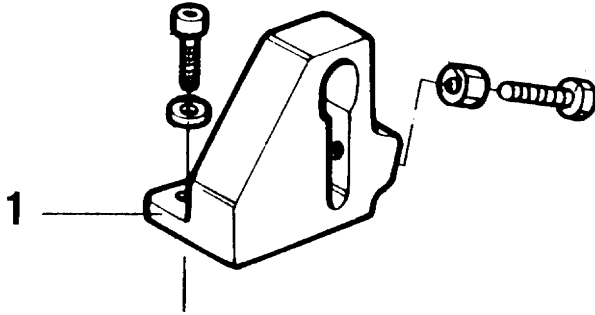
GROUP CODE	GROUP DESCRIPTION		
S0K01004	Torsion bar housing kit		
			
POS.	ITEMS CODE	ITEMS DESCRIPTION	Q.ty
1	FM020001	Torsion bar housing	1

UPPER HOOD GROUP

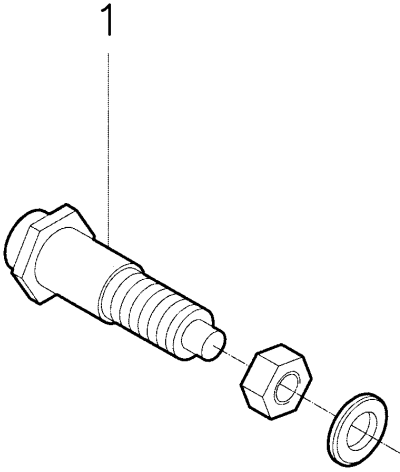
GROUP CODE	GROUP DESCRIPTION		
S0K01005	Hood rotation left pin kit		
			
POS.	ITEMS CODE	ITEMS DESCRIPTION	Q.ty
1	FM200094	Hood rotation left pin	1

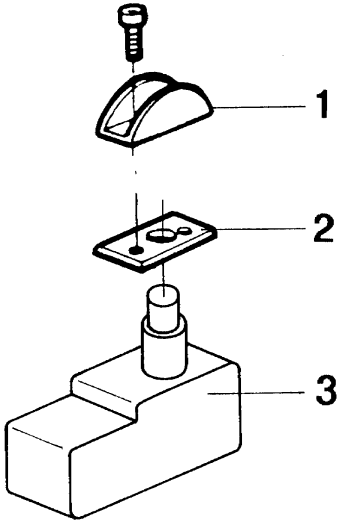
GROUP CODE	GROUP DESCRIPTION		
S0K01208	Electrica microswitch kit		
			
POS.	ITEMS CODE	ITEMS DESCRIPTION	Q.ty
1	FM230001	Microswitch guard	1
2	FM280216	Microswitch plate	1
3	FE220137	Microswitch	1

UPPER HOOD GROUP

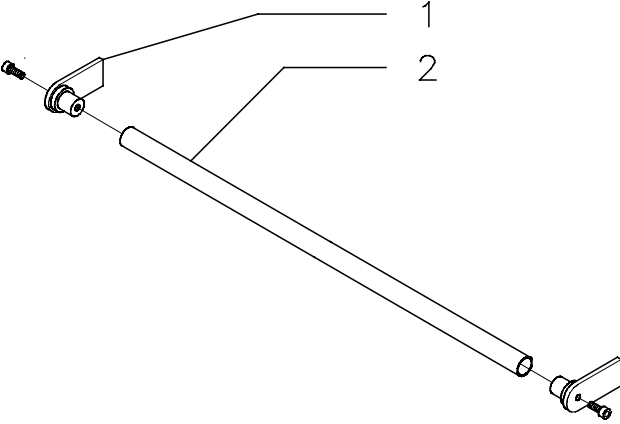
GROUP CODE	GROUP DESCRIPTION		
S02A0402	Hood handle kit		
			
POS.	ITEMS CODE	ITEMS DESCRIPTION	Q.ty
1	FM340005	Bush	2
2	FM150003	Handle	1

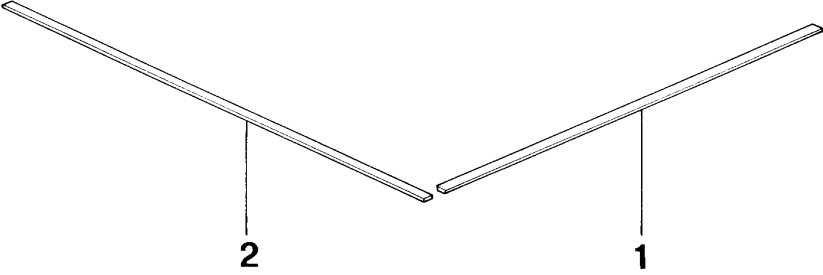
GROUP CODE	GROUP DESCRIPTION		
S02A0404	Teflon kit		
			
POS.	ITEMS CODE	ITEMS DESCRIPTION	Q.ty
1	FM240003	Teflon lining L530	1
2	FM240004	Teflon lining L570	1

UPPER HOOD GROUP

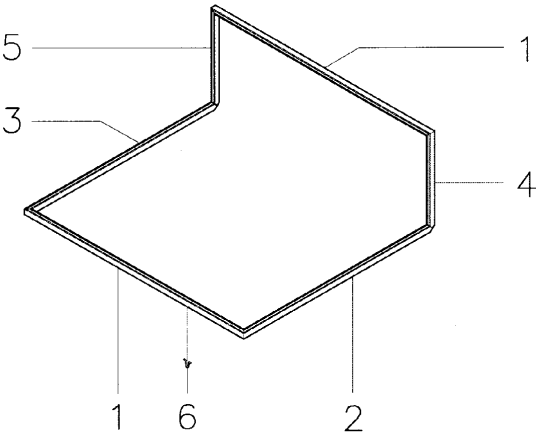
GROUP CODE	GROUP DESCRIPTION		
S02A0804	Lock channels kit		
			
POS.	ITEMS CODE	ITEMS DESCRIPTION	Q.ty
1	FM220305	Front and rear lock channel	2
2	FM220316	Right horizontal lock channel	1
3	FM220317	Left horizontal lock channel	1
4	FM220318	Right vertical lock channel	1
5	FM220319	Left vertical lock channel	1
6	FM630004	Fastener	16

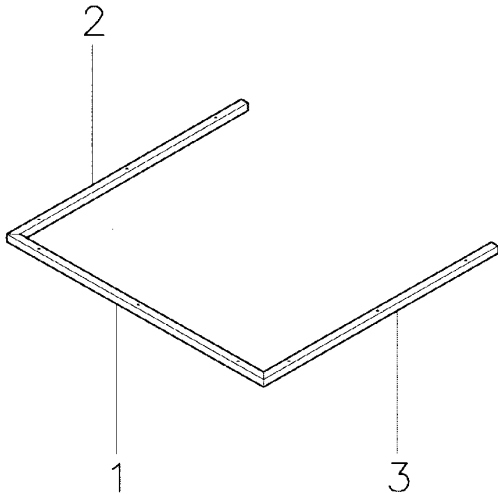
GROUP CODE	GROUP DESCRIPTION		
S02A0806	Rubber holder channels kit		
			
POS.	ITEMS CODE	ITEMS DESCRIPTION	Q.ty
1	FM220210	Front rubber holder channel	1
2	FM220245	Left rubber holder channel	1
3	FM220246	Right rubber holder channel	1

FILM ROLL SUPPORT GROUP

GROUP CODE	GROUP DESCRIPTION		
S0K00604	Slotted microperforator kit		
POS.	ITEMS CODE	ITEMS DESCRIPTION	Q.ty
1	FM340003	Eccentric bush	1
2	FM160071	Microperforator wheel	1
3	FM350050	Rubber ring	1
4	FM520005	Shafts seeger ring	1

GROUP CODE	GROUP DESCRIPTION		
S0K00605	Microperforator with needles kit		
POS.	ITEMS CODE	ITEMS DESCRIPTION	Q.ty
1	FM095137	Carter	1
2	FM340001	Centred bush	1
3	FM160007	Wheels with needles	1
4	FM520005	Shafts seeger ring	1

FILM ROLL SUPPORT GROUP

GROUP CODE	GROUP DESCRIPTION		
S02A0803	Film roll tube kit		
POS.	ITEMS CODE	ITEMS DESCRIPTION	Q.ty
1	FM250071	Film roll holder tube	1
2	FM340010	Centering cone	2

GROUP CODE	GROUP DESCRIPTION		
S02A0807	Orange microperforator support kit		
S02B0807	Grey microperforator support kit		
S02I0807	Inox microperforator support kit		
POS.	ITEMS CODE	ITEMS DESCRIPTION	Q.ty
1	FM030056	Microperforator rod	2
2	FM280072	Orange right microperforator square	1
	FM280075	Grey right microperforator square	1
	FM280142	Inox right microperforator square	1
3	FM280073	Orange left microperforator square	1
	FM280074	Grey left microperforator square	1
	FM280143	Inox left microperforator square	1

FILM ROLL SUPPORT GROUP

GROUP CODE	GROUP DESCRIPTION		
S02A0808	Sliding guides + corners kit		
POS.	ITEMS CODE	ITEMS DESCRIPTION	Q.ty
1	FM140004	Female guide L600	2
2	FM140006	Male guide L600	2
3	FM220522	Upper male guide corner	1
4	FM220523	Upper female guide corner	1
5	FM220524	"Z" shaped channel for male guide	1

GROUP CODE	GROUP DESCRIPTION		
S02A0909	Coupled guides kit		
POS.	ITEMS CODE	ITEMS DESCRIPTION	Q.ty
1	FM140004	Female guide L600	2
2	FM140006	Male guide L600	2

FILM ROLL SUPPORT GROUP

GROUP CODE	GROUP DESCRIPTION
PB02A083	Orange film roll support kit
PB02B083	Grey film roll support kit
PB02I082	Inox film roll support kit
PB02I083	Orange film roll support kit and inox packaging plate
PB02I183	Grey film roll support kit and inox packaging plate

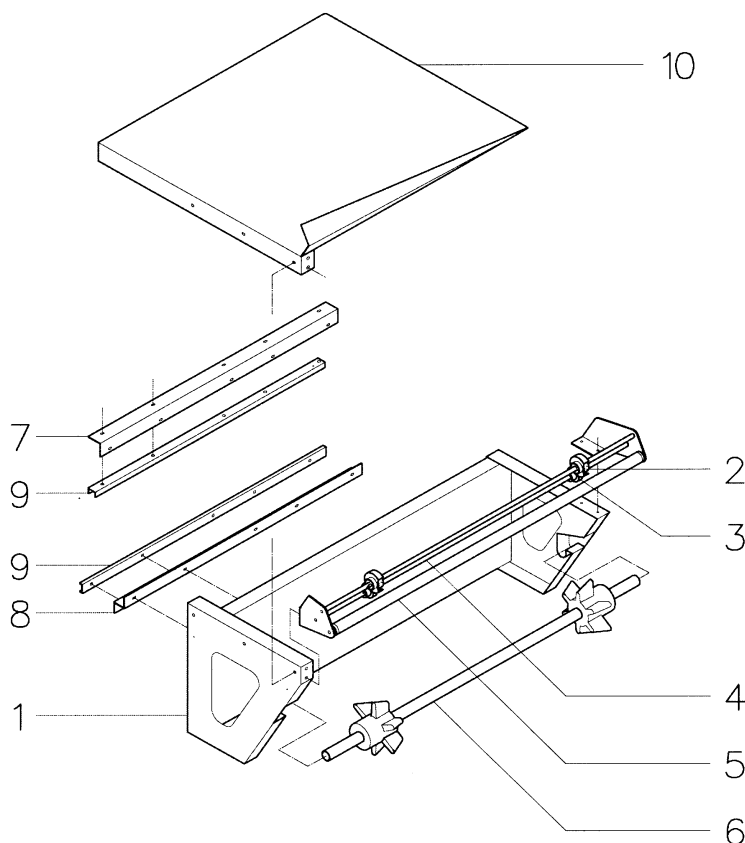

POS.	ITEMS CODE	ITEMS DESCRIPTION	Q.ty
1	FM090379	Orange film roll support	1
	FM090380	Grey film roll support	1
	FM090385	Inox film roll support	1
2	S0K00605	Microperforator with needles kit	2
3	S0K00604	Slotted microperforator kit	2
4	S02A0807	Orange microperforator support kit	1
	S02B0807	Grey microperforator support kit	1
	S02I0807	Inox microperforator support kit	1
5	FM710319	Film transmission roller	1
6	S02A0803	Film roll tube kit	1
7	FM220522	Upper male guide corner	1
8	FM220524	"Z" shaped channel for male guide	1
9	FM140006	Female guide L600	2
10	FM090182	Orange packaging plate	1
	FM090183	Grey packaging plate	1
	FM090185	Inox packaging plate	1

FILM ROLL SUPPORT GROUP

GROUP CODE	GROUP DESCRIPTION
PB02N080	Second film roll support kit

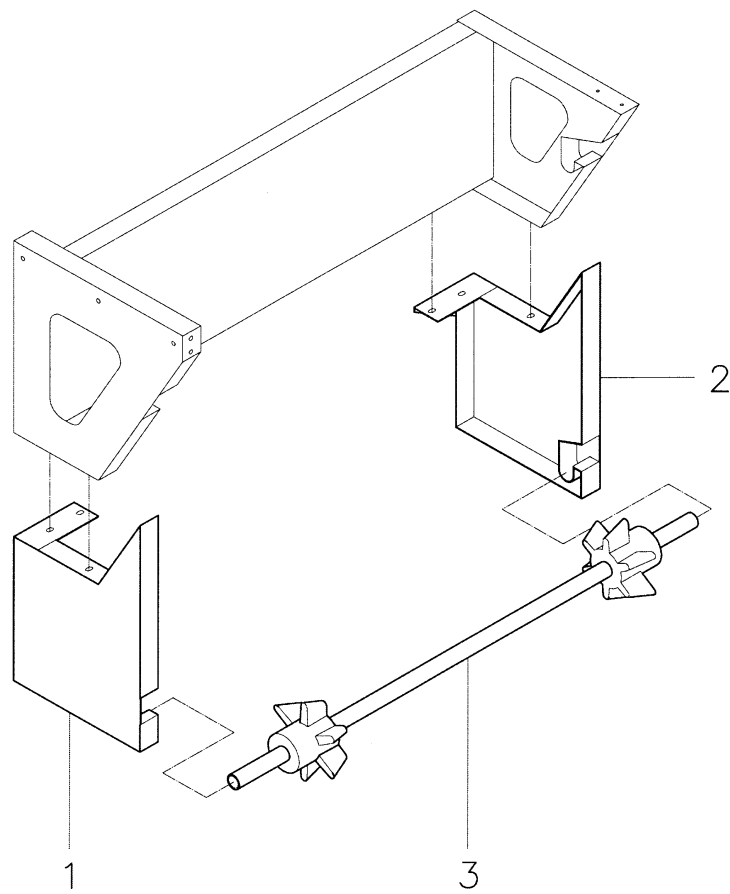

POS.	ITEMS CODE	ITEMS DESCRIPTION	Q.ty
1	FM090346	Left second film roll support	1
2	FM090345	Right second film roll support	1
3	S02A0803	Film roll holder kit	1

HEATING CHAMBER GROUP

GROUP CODE	GROUP DESCRIPTION
PR020A85	230V heating chamber kit
PR020D85	200V heating chamber kit
PR020E85	115V heating chamber kit

Valid from serial number 1132 dated 09.1999.

and the same for 935÷964, 985÷1004, 1030÷1039, 1044÷1053, 1074÷1083, 1104÷1123.

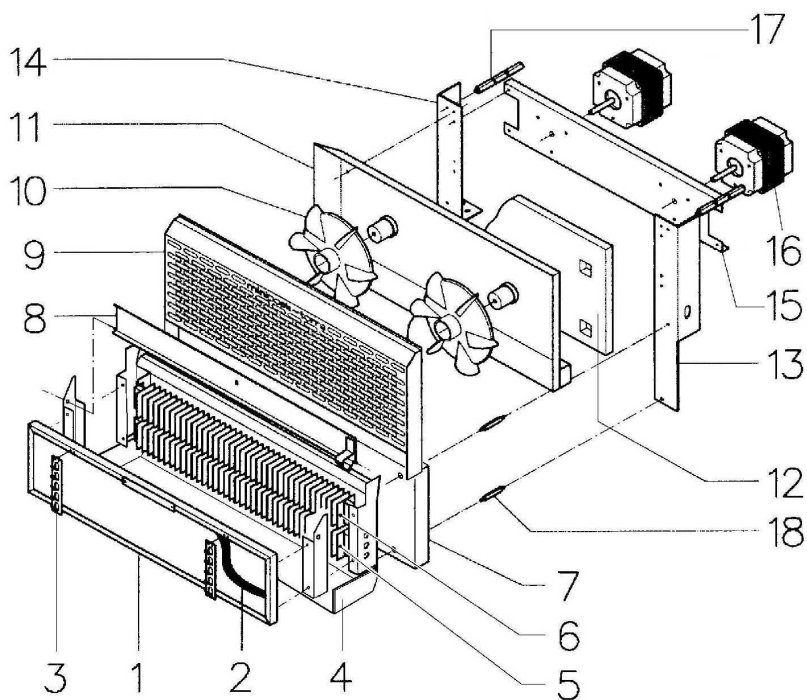

POS.	ITEMS CODE	ITEMS DESCRIPTION	Q.ty
1	FM090275	Heaters front plate	1
2	FM195066	Glass wool panel	1
3	FM290161	Screened plate rear support	2
4	FM090293	Heaters rear plate	1
5	FE381011	W1700 V230 heater	1
	FE381013	W1700 V115 heater	1
	FE381019	W1700 V200 heater	1
6	FE381012	W1100 V230 heater	1
	FE381014	W1100 V115 heater	1
	FE381020	W1100 V200 heater	1
7	FM195067	Rock wool panel	1
8	FM280150	Heating chamber flap	1
9	FM230009	Fan grid	1
10	S02A0802	Fan + bush kit	2
11	FM280152	Air diffuser	1
12	FM195068	Glass wool panel	1
13	FM220556	Heating chamber right corner	1
14	FM220557	Heating chamber left corner	1
15	FM300173	Motor support cross member	1
16	FE241051	230V motor	2
	FE241053	200V motor	2
	FE241055	115V motor	2
17	FM160128	Rear carter spacer	2
18	FM160180	Heating chamber spacer	4

HEATING CHAMBER GROUP

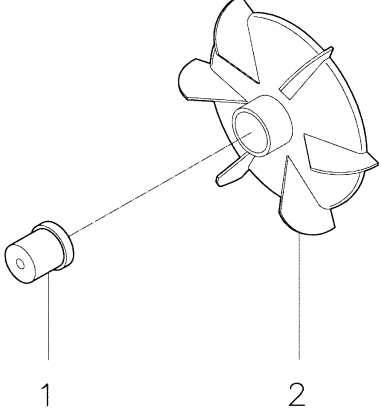
GROUP CODE	GROUP DESCRIPTION		
S02A0802	Fan + bush kit		
			
POS.	ITEMS CODE	ITEMS DESCRIPTION	Q.ty
1	FM340044	Fan bush	1
2	FM830004	Fan	1

GROUP CODE	GROUP DESCRIPTION
AV020A80	230V film winder group
AV020E80	115V film winder group

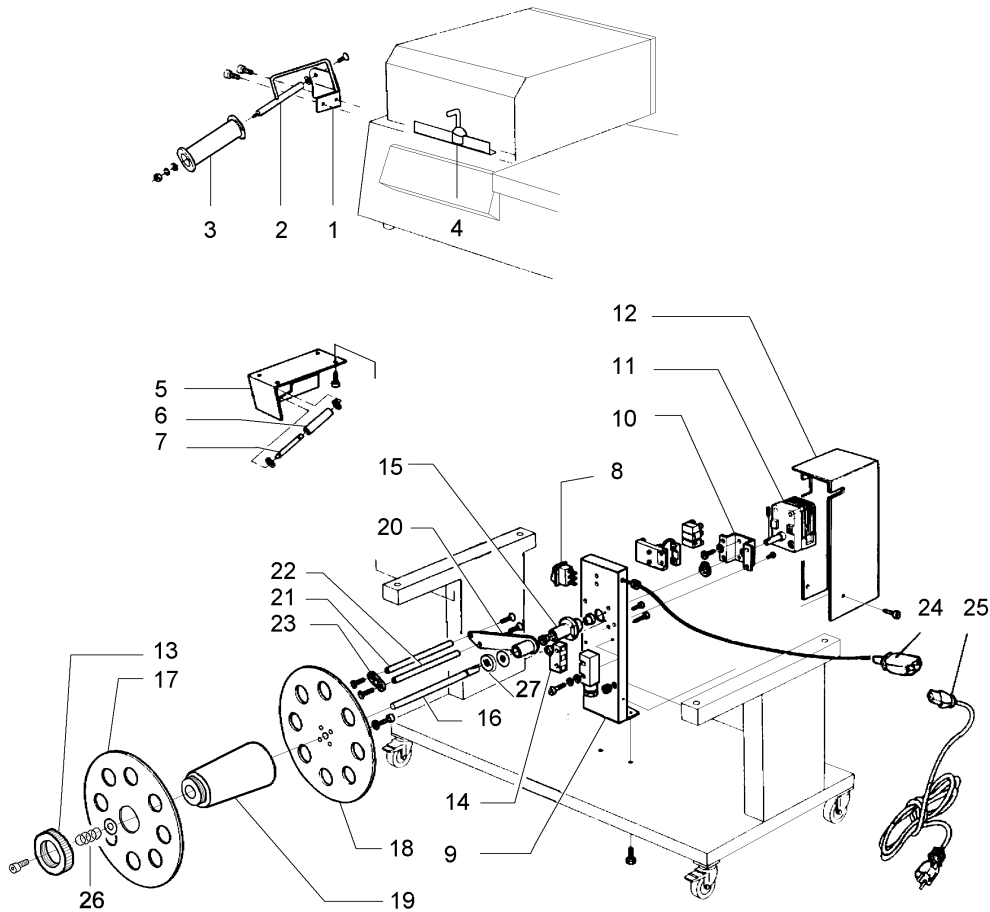

POS.	ITEMS CODE	ITEMS DESCRIPTION	Q.ty
1	FM290244	Film transmission support	1
2	FM200069	Transmission roller pin	1
3	FM250049	Transmission roller	1
4	S0K00407	Film roll guide group	1
5	FM290177	Film transmission support	1
6	FM250038	Transmission roller	1
7	FM200060	Transmission roller pin	1
8	FE190032	Switch	1
9	FM290175	Winder support	1
10	FM290107	Gearmotor support	1
11	FE250016	230V gearmotor	1
	FE250017	115V gearmotor	1
12	FM095138	Gearmotor carter	1
13	FM160104	Blocking ring nut	1
14	FE220105	Microswitch	1
15	FM290172	Tightener lever support	1
16	FM010041	Winder shaft	1
17	FM120022	Mobile flange	1
18	FM120015	Fix flange	1
19	FM250121	Hub	1
20	FM060027	Winder lever	1
21	FM250074	Winder roller	1
22	FM030063	Winder lever rod	2
23	FM280326	Connecting plate	1
24	FE310121	Cable + plug + prod	1
25	FE310112	Cable + Shuko + plug	1
26	FM160086	Spring	1
27	FM160111	Winder washer	1

GROUP CODE	GROUP DESCRIPTION
CA02N002	Orange trolley
CA02N003	Grey trolley
CA02N006	Inox trolley

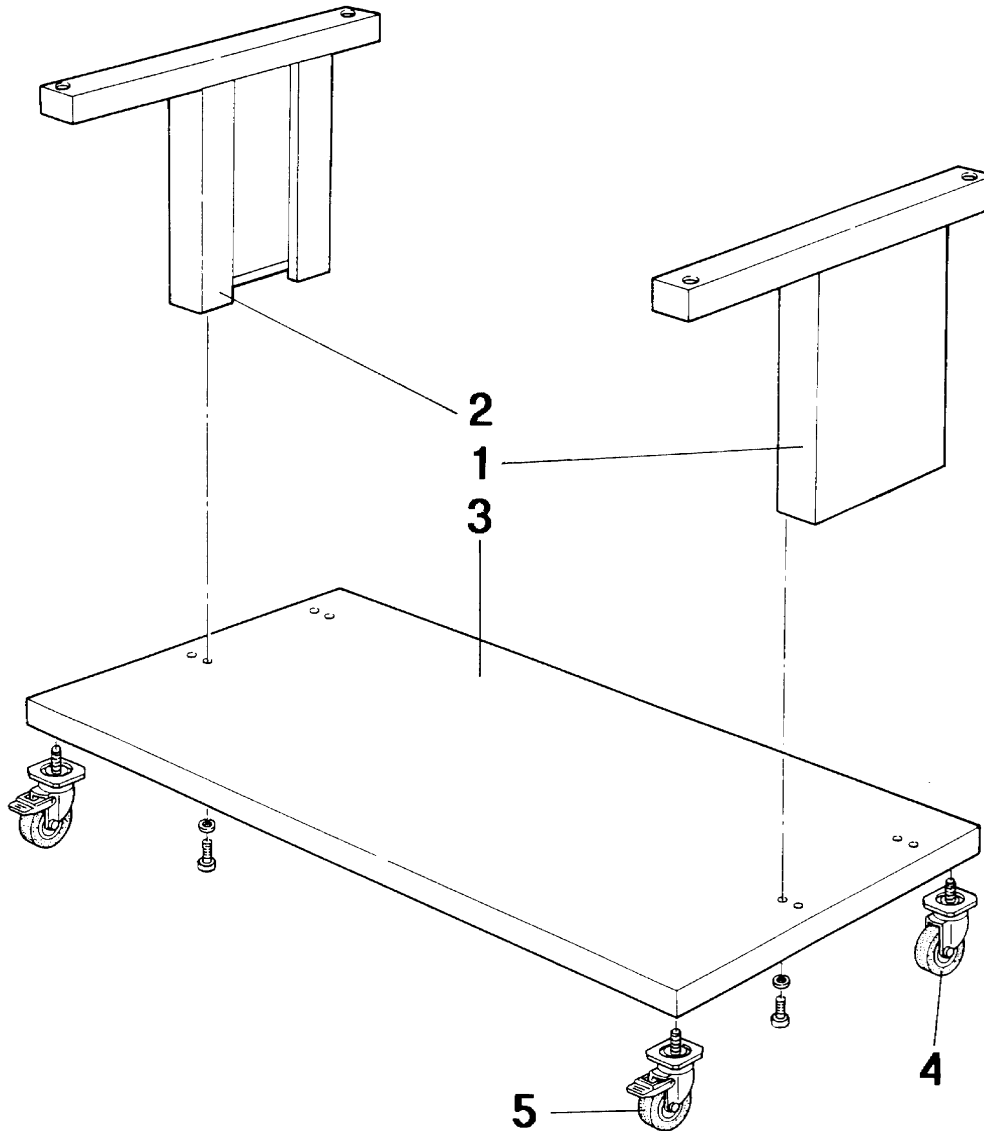

POS.	ITEMS CODE	ITEMS DESCRIPTION	Q.ty
1	FM091070	Orange trolley right vertical rod	1
	FM091073	Grey trolley right vertical rod	1
	FM091079	Inox trolley right vertical rod	1
2	FM091071	Orange trolley left vertical rod	1
	FM091074	Grey trolley left vertical rod	1
	FM091080	Inox trolley left vertical rod	1
3	FM091072	Orange base plane	1
	FM091075	Grey base plane	1
	FM091081	Inox base plane	1
4	FM770521	Wheel	2
5	FM770522	Wheel + brake	2

MACHINE DETAIL DRAWING

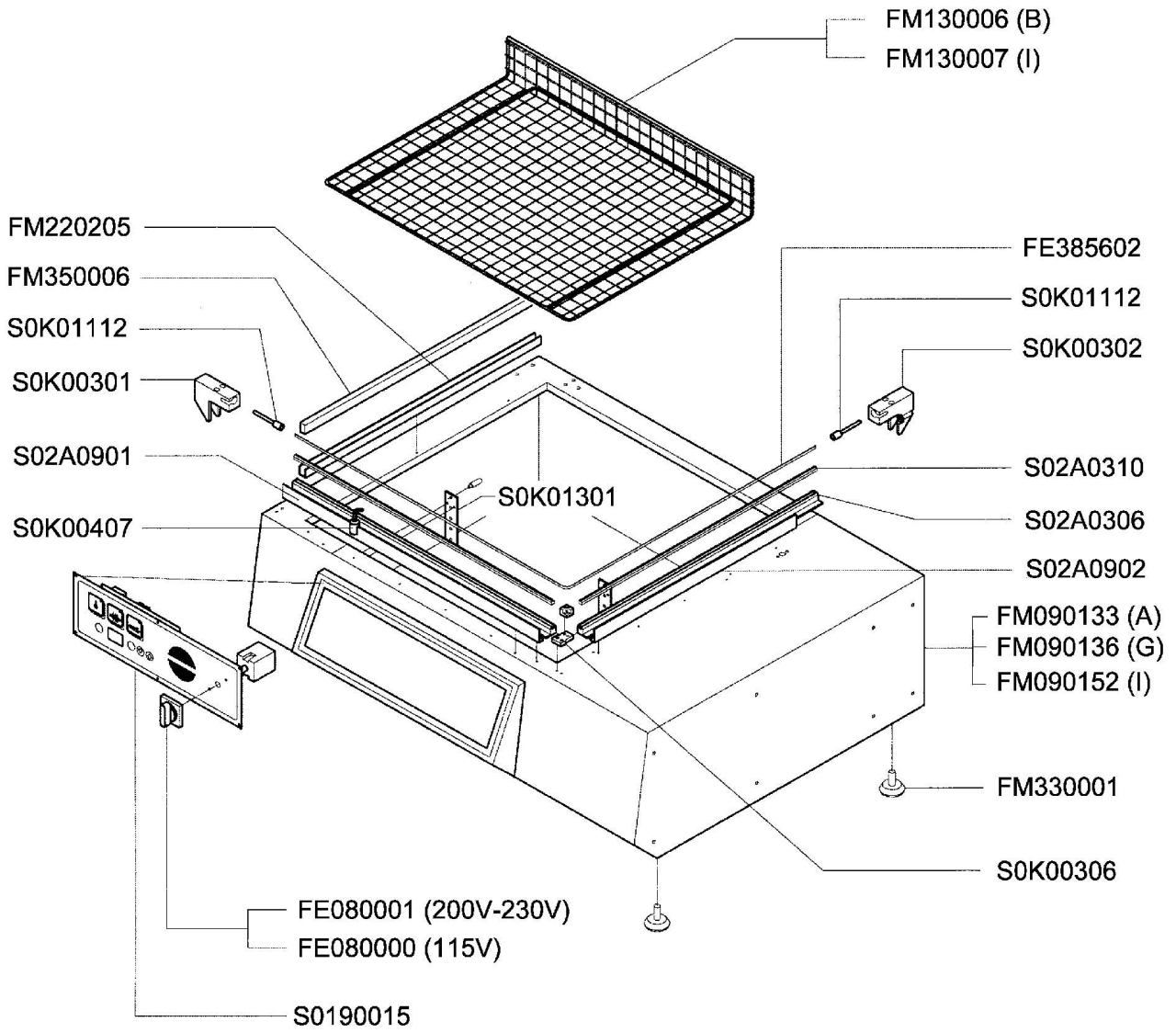

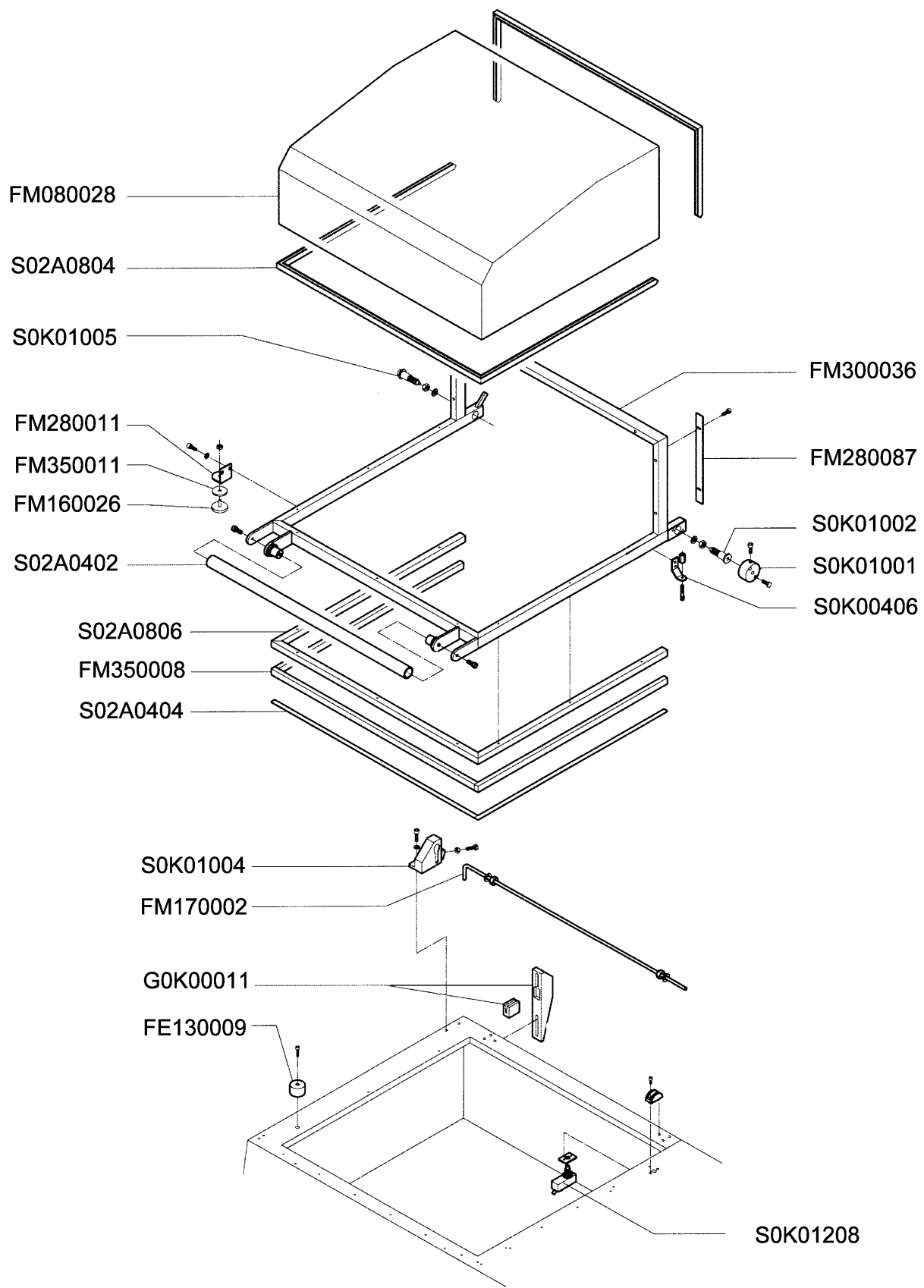

Valid from serial number 1132 dated 09.1999.
 and the same for 935-964, 985-1004, 1030-1039, 1044-1053, 1074-1083, 1104-1123.

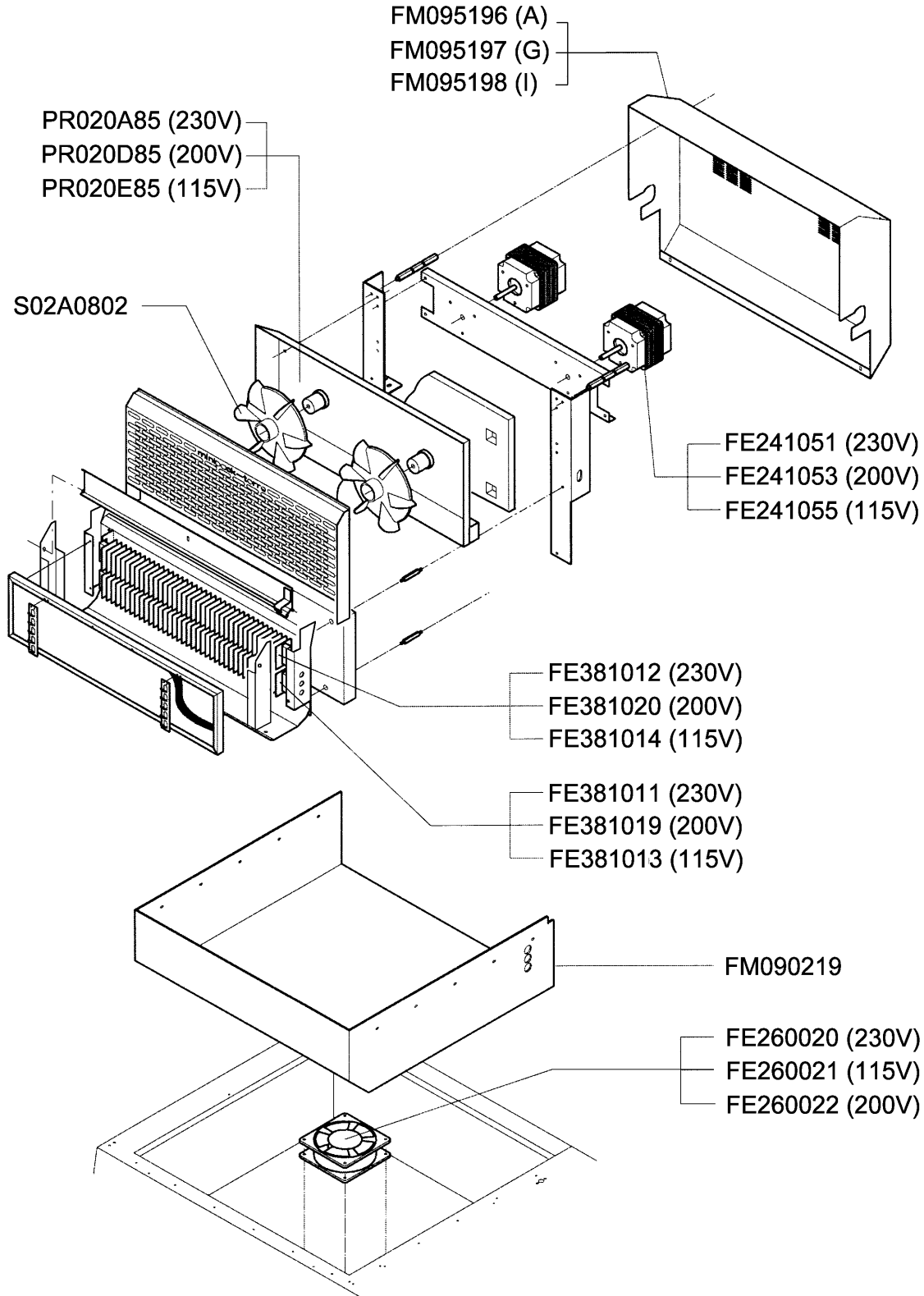

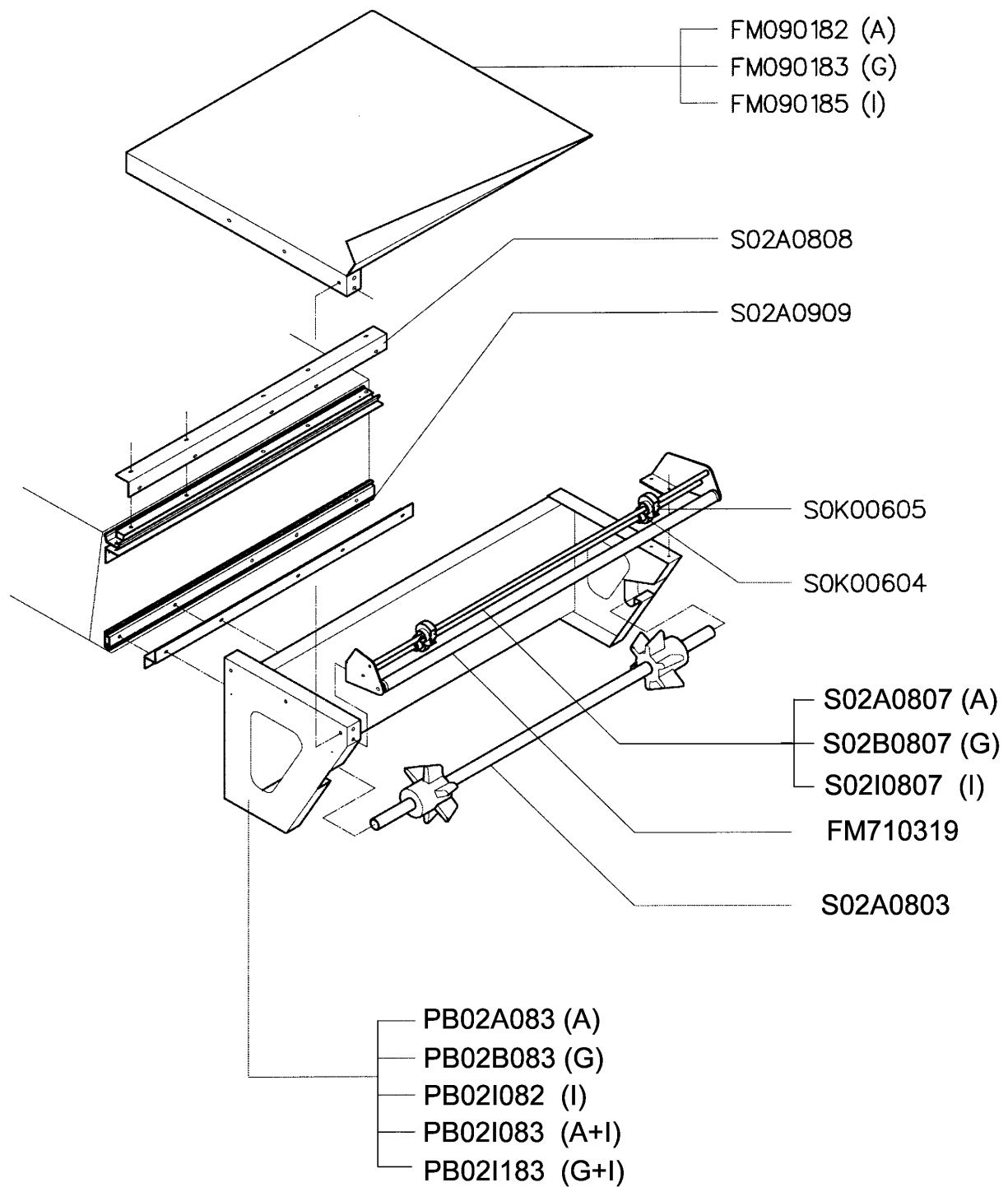

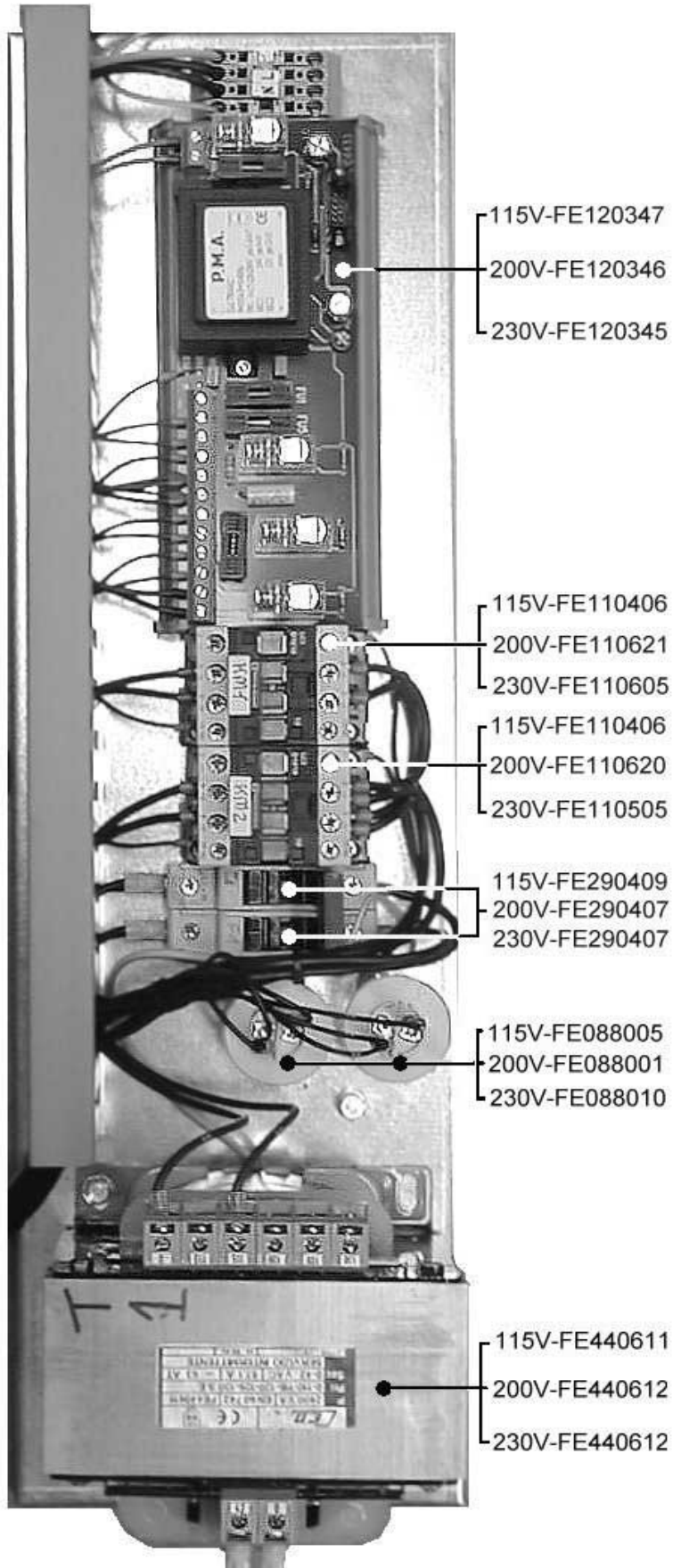

WIRING DIAGRAM

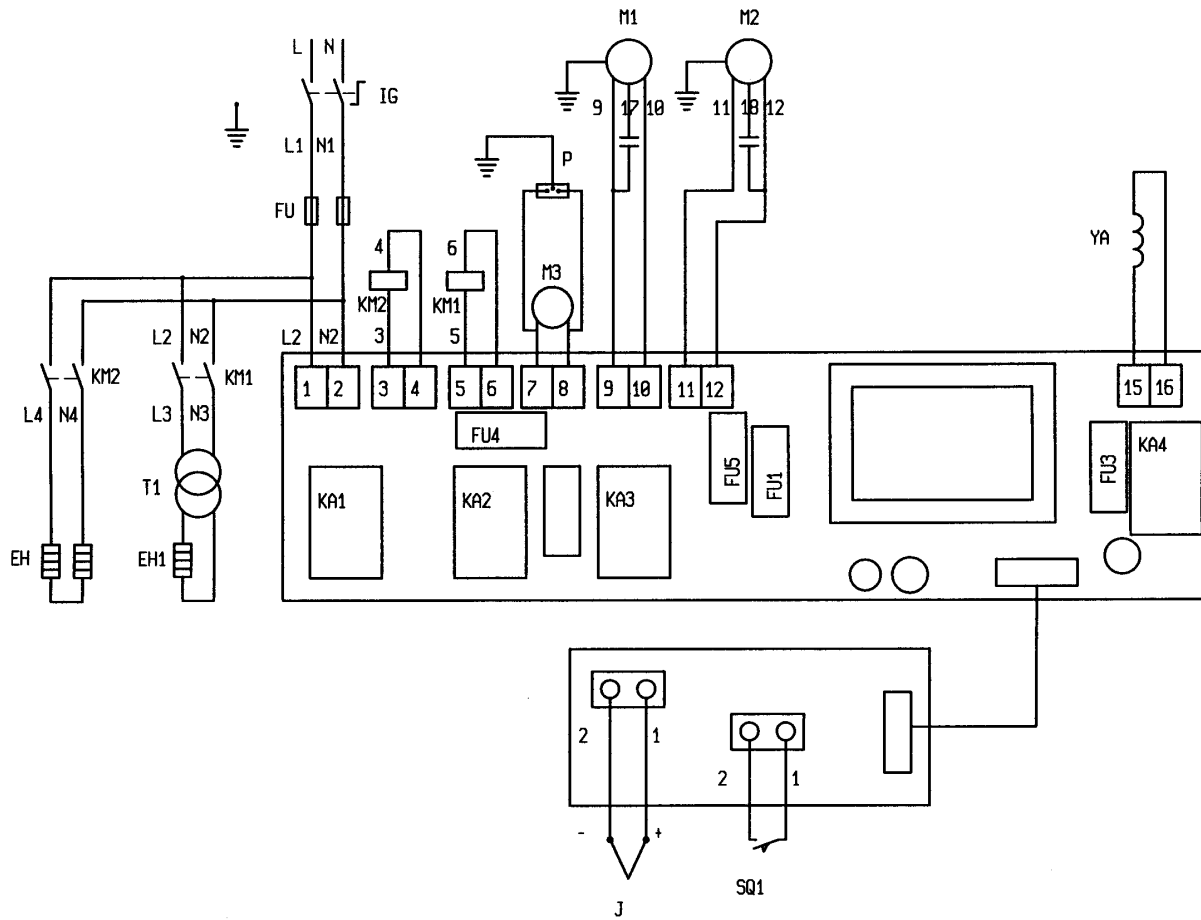

	115V	200V	230V
FU	25A 450V AM	16A 450V AM	16A 450V AM
FU1	500mA 250V T	315mA 250V T	315mA 250V T
FU3	500mA 250V T	500mA 250V T	500mA 250V T
FU4	1A 250V T	500mA 250V T	500mA 250V T
FU5	4A 250V T	2A 250V T	2A 250V T

- | | |
|------------------------------|--------------------------------|
| IG Main switch | T1 Cutting transformer |
| FU Line fuse 10.3X38 | M1 Fan motor |
| FU1 Board fuse 5X20 | M2 Fan motor |
| FU3 Magnet fuse 5X20 | M3 Ventilator motor |
| FU4 Auxiliary plug fuse 5X20 | YA Shrinking magnet |
| FU5 Motor fuse 5X20 | J Thermocouple |
| EH Oven resistors | SQ1 Machine cycle limit switch |
| EH1 Cutting heater | |



minipack-torre S.p.A.

Via provinciale, 54-24044 DALMINE (BG)-ITALY
Tel. (035) 563525 (4 linee r.a.) TLX303055 MIPACK I
Fax (035) 564945-Cod.Fisc.01633550163