



**Minipack-torre S.p.A.**  
Via Provinciale, 54 - 24044 Dalmine (BG) - Italy  
Tel. (035) 563525 – Fax (035) 564945  
E-mail: [info@minipack-torre.it](mailto:info@minipack-torre.it)  
<http://www.minipack-torre.it>



## **mod.: Galileo Classic**

Valid from serial number 1704 dated 05.2007 (single packaging plate version),  
up to serial number 2987 dated 01.2010.

## **mod.: Galileo Office**

Valid from serial number 1887 dated 07.2007 (single packaging plate version),  
up to serial number 2987 dated 01.2010.

## **mod.: Galileo Food**

Valid from serial number 1797 dated 06.2007 (single packaging plate version),  
up to serial number 2987 dated 01.2010.

### **Spare parts catalogue**

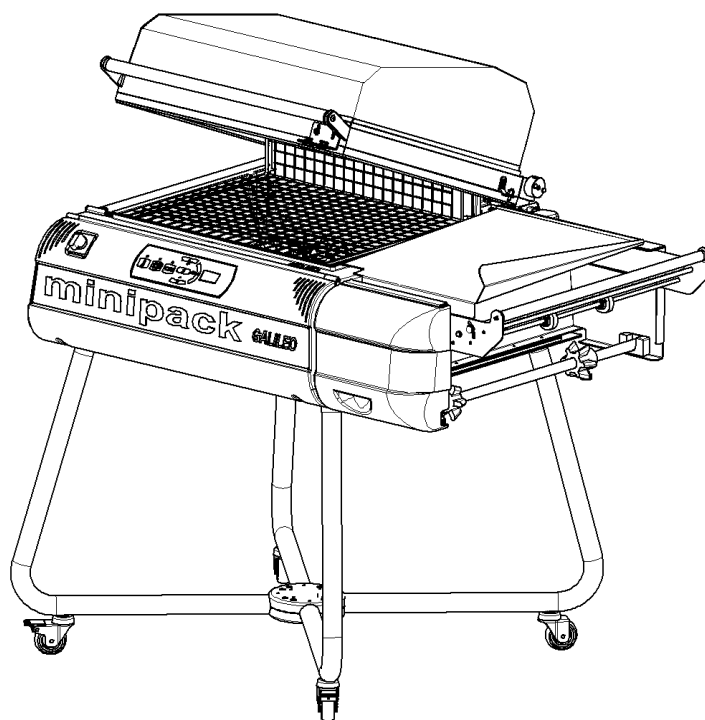

CAREFULLY READ THIS CATALOGUE BEFORE ORDERING ANY SPARE PART



DOC. N. FM112109  
REV. 02  
ED. 01.2010

<b>ITEMS DESCRIPTION</b>	<b>SCHEME 1</b>
--------------------------	-----------------

**Heating chambers**

**230V / 230V ETL version:** Valid from s.n.865 (Galileo Classic) dated 05.2006 up to s.n.2690 dated 10.2008.  
Valid from s.n.760 (Galileo Office/Food) dated 04.2006 up to s.n.2690 dated 10.2008.  
**200V version:** Valid from serial number 865 (Galileo Classic) dated 05.2006.  
Valid from s.n.760 (Galileo Office/Food) dated 04.2006

Note: for the 230V and 230V ETL version only, when replacing 1 of the 2 heaters, or both (pos. 1.10 and 1.11), please, order the spare part code nr. KR260A10 (one unit).

<b>Pos.</b>	<b>Code</b>	<b>Description</b>
1.01	P0K00309	Front and back terminal pre-assembly
1.01.01	FM650111	Gasket OR 2018
1.01.02	FM290522	Blade stretcher support
1.01.03	FM170178	Compression spring
1.01.04	FM850703	Screw TC M3X8
1.01.05	FM210017	Blade stretcher small piston
1.02	P0K00350	Central terminal pre-assembly
1.02.01	FM040191	Central terminal
1.02.02	FM650111	Gasket OR 2018
1.02.03	FM850703	Screw TC M3X8
1.03	FM340505	Plug x blade stretcher support
1.04	FM220630	Insulator holder section
1.05	FM050118	Blade holder insulator
1.06	FE385654	Sealing blade
1.07	FM130016	Reticulated plate
1.08	FM195104	Glass wool panel
1.09	FM090296	Front heater plate
1.10	KR260A10 FE381019	(230V-230V ETL) Heat sink kit Heater W1700 V123 (valid for 200V)
1.11	KR260A10 FE381020	(230V-230V ETL) Heat sink kit Heater with thermocouple W1100 V77 (valid for 200V)
1.12	FM090297	Back heater plate
1.13	FM090298	Right heating chamber cover
1.14	FM090299	Left heating chamber cover
1.16	FM195105	Insulating panel
1.17	FM281334	Heating chamber paddle
1.18	FM170179	Constrast spring
1.19	FM350604	Product support

**Heating chambers**

**230V / 230V ETL version:**

Valid from s.n.865 (Galileo Classic) dated 05.2006 up to s.n.2690 dated 10.2008.

Valid from s.n.760 (Galileo Office/Food) dated 04.2006 up to s.n.2690 dated 10.2008.

**200V version:**

Valid from serial number 865 (Galileo Classic) dated 05.2006.

Valid from s.n.760 (Galileo Office/Food) dated 04.2006

*Note: for the 230V and 230V ETL version only, when replacing 1 of the 2 heaters, or both (pos. 1.10 and 1.11), please, order the spare part code nr. KR260A10 (one unit).*

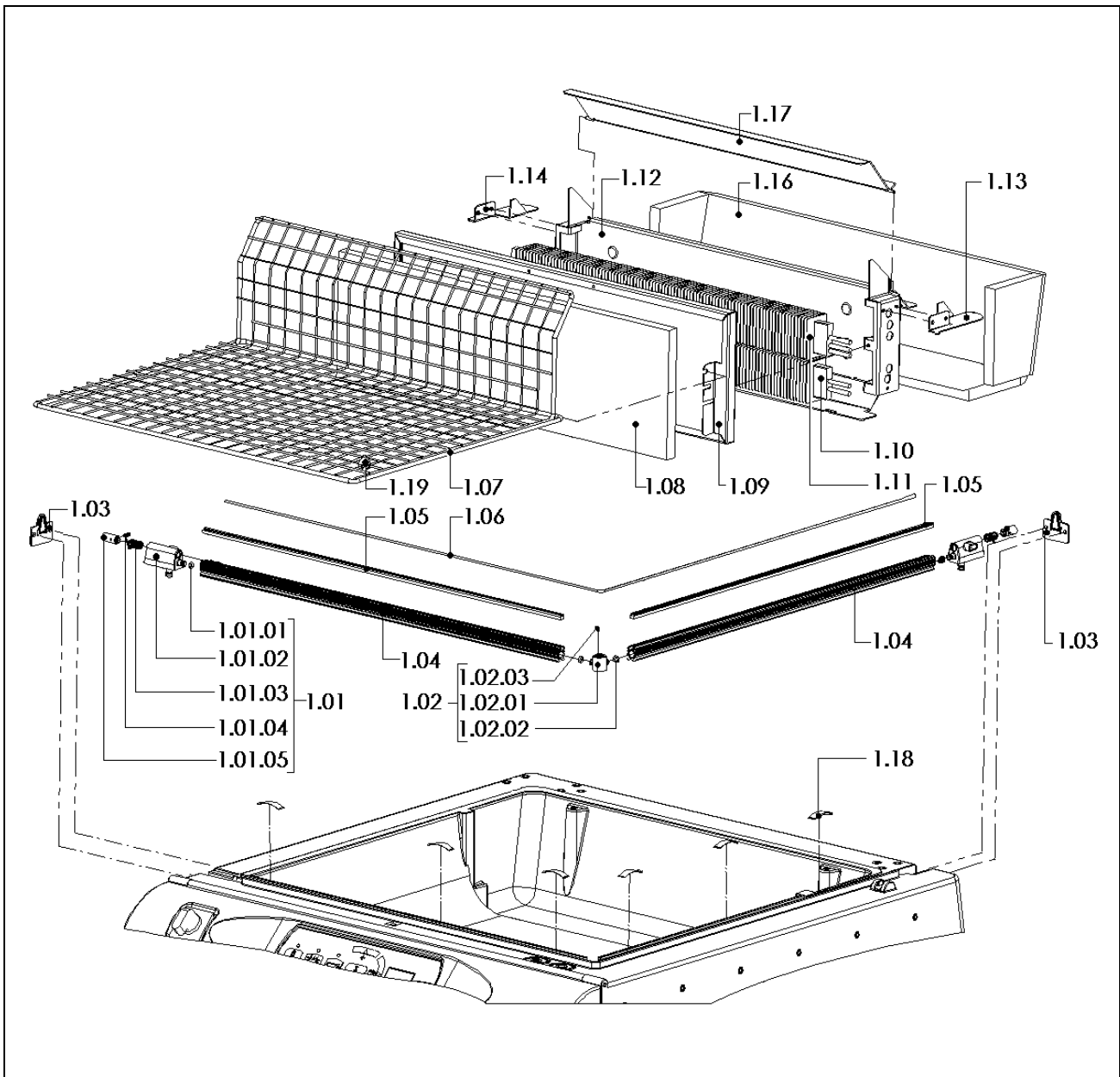

**ITEMS DESCRIPTION****SCHEME 1.1****New style heating chambers****230V / 230V ETL version:** Valid from serial number 2691 dated 10.2008.

<b>Pos.</b>	<b>Code</b>	<b>Description</b>
1.01	P0K00309	Front and back terminal pre-assembly
1.01.01	FM650111	Gasket OR 2018
1.01.02	FM290522	Blade stretcher support
1.01.03	FM170178	Compression spring
1.01.04	FM850703	Screw TC M3X8
1.01.05	FM210017	Blade stretcher small piston
1.02	P0K00350	Central terminal pre-assembly
1.02.01	FM040191	Central terminal
1.02.02	FM650111	Gasket OR 2018
1.02.03	FM850703	Screw TC M3X8
1.03	FM340505	Plug x blade stretcher support
1.04	FM220630	Insulator holder section
1.05	FM050118	Blade holder insulator
1.06	FE385654	Sealing blade
1.07	FM130016	Reticulated plate
1.08	FM195104	Glass wool panel
1.09	FM090296	Front heater plate
1.10	S0K01210	Safety thermostat
1.11	FM390020	W2550 V230 Heat sink
1.12	FM091208	Back heater plate
1.13	FM090298	Right heating chamber cover
1.14	FM090299	Left heating chamber cover
1.15	FE435011	Thermocouple
1.16	FM195105	Insulating panel
1.17	FM281334	Heating chamber paddle
1.18	FM170179	Constrast spring
1.19	FM350604	Product support

**New style heating chambers**  
**230V / 230V ETL version:** Valid from serial number 2691 dated 10.2008.

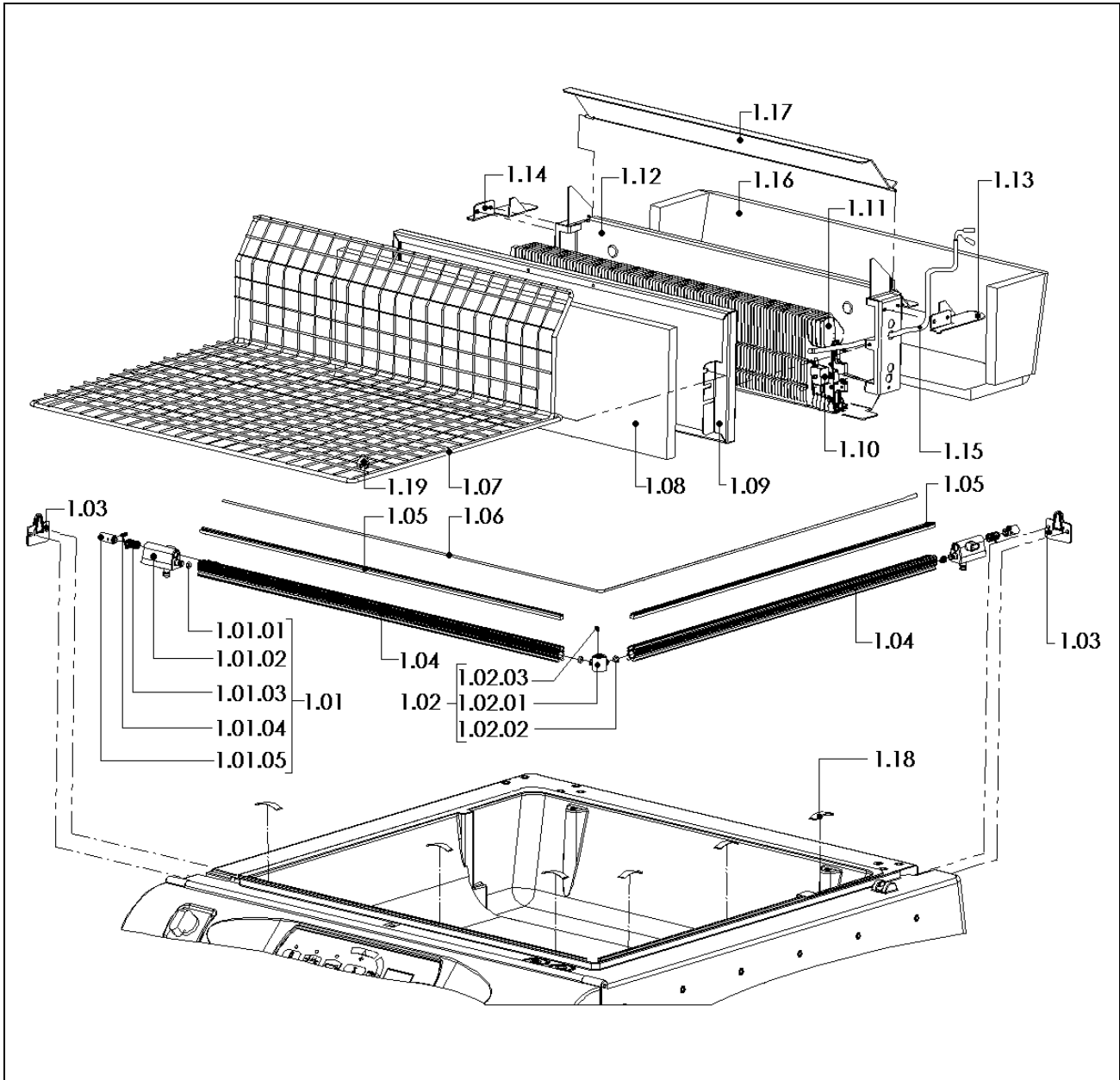

<b>ITEMS DESCRIPTION</b>	<b>SCHEME 2</b>
--------------------------	-----------------

<b>Pos.</b>	<b>Code</b>	<b>Description</b>
2.01	KR260017	Hood and section kit
2.02	FM081042	Upper hood
2.03	KR260006	Glass stop section kit
2.03.01	FM220613	Glass stop front section
2.03.02	FM220614	Glass stop side section
2.03.03	FM630004	Clip
2.04	FM300213	Frame per upper hood
2.05	FM540007	Bush
2.06	KR260007	Tracer point kit x microswitch
2.06.01	FM160001	Ring nut x tracer point
2.06.02	FM290524	Square x tracer point
2.06.03	FM160224	Microswitch tracer point
2.06.04	FM850914	Screw TC+ M4X12
2.06.05	FM859002	Spring washer Ø4
2.07	KR260013	Paddle opening lever kit
2.07.01	FM281404	Paddle opening lever
2.07.02	FM850914	Screw TC+ M4X12
2.07.03	FM859002	Spring washer Ø4
2.07.04	FM858502	Flat washer Ø4
2.08	KR260009	Upper rubber holder section kit
2.08.01	FM220210	Front and back rubber holder section
2.08.02	FM220222	Side rubber holder section
2.09	S02A0402	Handgrip kit x hood
2.09.01	FM150003	Handgrip
2.09.02	FM340005	Bush x handgrip
2.09.03	FM870101	Screw M6X15
2.10	FM290523	Electromagnet contrast support
2.11	FM170177	Compression spring
2.12	FM160026	Electromagnet contrast
2.13	FE130013	Elettromagnet
2.14	KR260010	Torsion bar housing kit
2.14.01	FM020001	Torsion bar housing
2.14.02	FM851216	Screw TCEI M6X20
2.14.03	FM858504	Flat washer Ø6
2.14.04	FM850111	Screw TE M8X50
2.14.05	FM855805	Low nut M8
2.15	FM290101	Hood support
2.16	FM170002	Torsion bar
2.17	FM250102	Tube x torsion bar
2.18	S0K01005	Left pin kit x hood rotation
2.18.01	FM200094	Left pin x hood rotation
2.18.02	FM858507	Flat washer Ø12
2.18.03	FM855710	Nut M12X1,25
2.19	S0K01002	Right pin kit x hood rotation
2.19.01	FM200052	Right pin x hood rotation
2.19.02	FM858507	Flat washer Ø12
2.19.03	FM855710	Nut M12X1,25
2.20	G0K00011	Hood shock absorber kit
2.20.01	FM290001	Rubber washer holder bracket G
2.20.02	FM350001	Shock absorber rubber washer
2.20.03	FM280304	Plate x bracket
2.20.04	FM851210	Screw TCEI M5X16
2.20.05	FM859003	Spring washer Ø5
2.21	S0K01001	Flange kit x torsion bar
2.21.01	FM120002	Flange x torsion bar
2.21.02	FM851213	Screw TCEI M6X14
2.21.03	FM850115	Screw TE M5X30
2.22	FM350021	Neoprene rubber 17X10 L.2300mm
2.23	KR260011	Upper hood teflon kit
2.23.01	FM240004	Teflon coating H.10mm L.570mm
2.24	S0K01208	Hood microswitch kit
	S0K01209	Hood microswitch kit (ETL version)
2.24.01	FE220137	Microswitch
	FE220127	Microswitch (ETL version)
2.24.02	FM280216	Plate x microswitch
2.24.03	FM850914	Screw TC+ M4X12

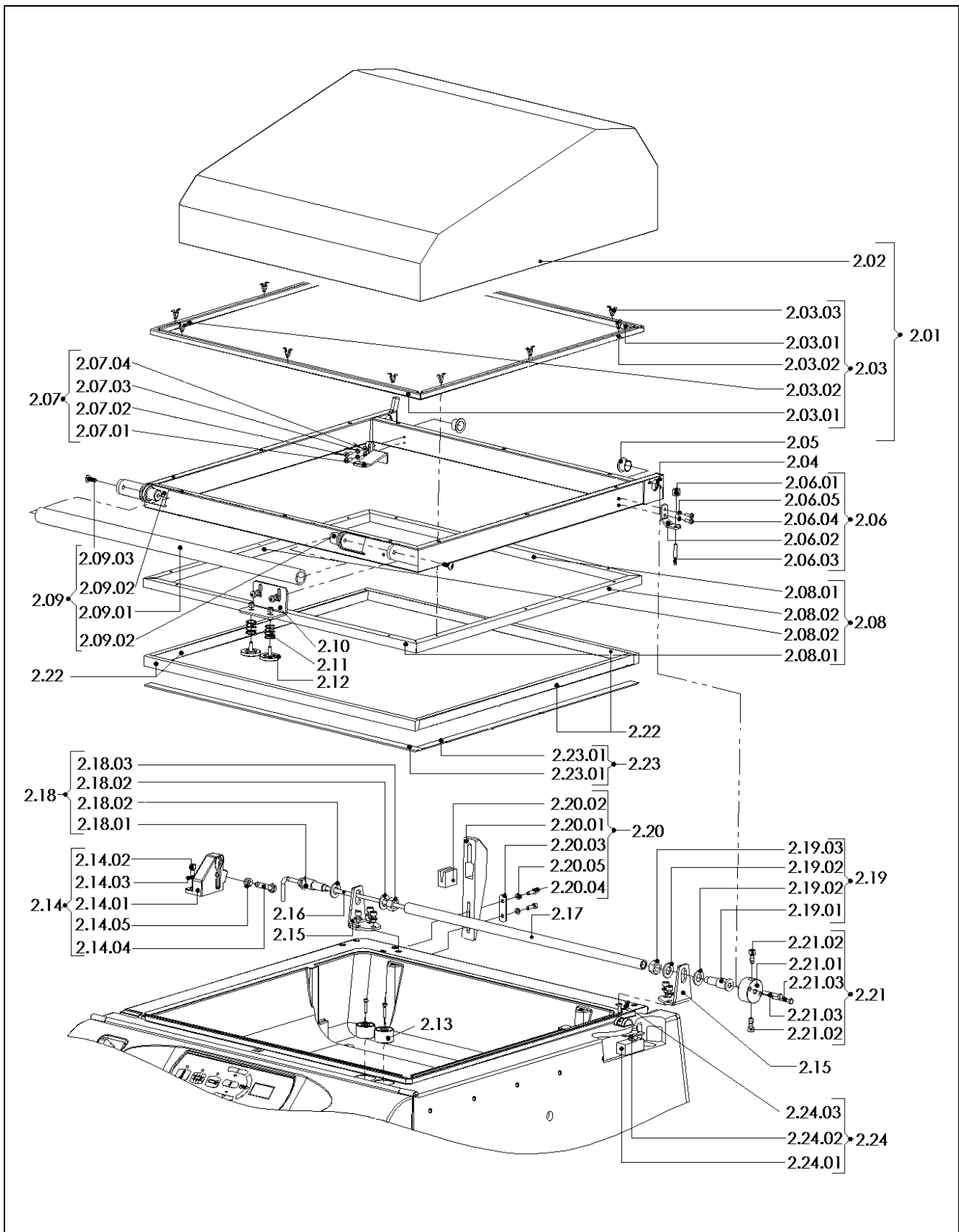

<b>ITEMS DESCRIPTION</b>	<b>SCHEME 3</b>
--------------------------	-----------------

<b>Pos.</b>	<b>Code</b>	<b>Description</b>
3.01	FM090758 FM090759	Reel support RAL2004L. Reel support RAL7035L.
3.03	FM090860 FM090861 FM090862	Packaging plate RAL2004L. Packaging plate RAL7035L. Stainless steel packaging plate
3.04	FM081013 FM081016	Front panel x reel support RAL2004B. Front panel x reel support RAL7035B.
3.05	FM710306	Transmission roller
3.07	FM095747	Micropuncher needle contrast
3.08	FM200267	Pin
3.09	FM510064	Handwheel M5X10
3.10	FM030073	Micropuncher rod
3.11	S0K00605	Small wheel kit with needles
3.11.01	FM340001	Bush
3.11.02	FM095137	Case
3.11.03	FM851803	Screw STEI M6X8
3.11.04	FM160007	Small wheel with needles
3.11.05	FM520005	Seeger for shafts Ø 14
3.12	KR260002	Reel holder roller kit
3.12.01	FM340010	Centering cone
3.12.02	FM250563	Reel holder roller
3.12.03	FM510065	Handwheel M6X20
3.13	FM340510	Support x reel holder roller
3.14	FM220609	Profile x guide
3.15	FM200265	Clamping pin
3.16	FM220610	Profile x internal guide
3.17	FM340506	Sliding block x internal guide profile
3.18	FM090966 FM090971	Square x guide RAL2004L. Square x guide RAL7035L.
3.19	KR260003	Reel support guide kit
3.19.01	FM140003	Female guide
3.19.02	FM140005	Male guide



( *single packaging plate version* )

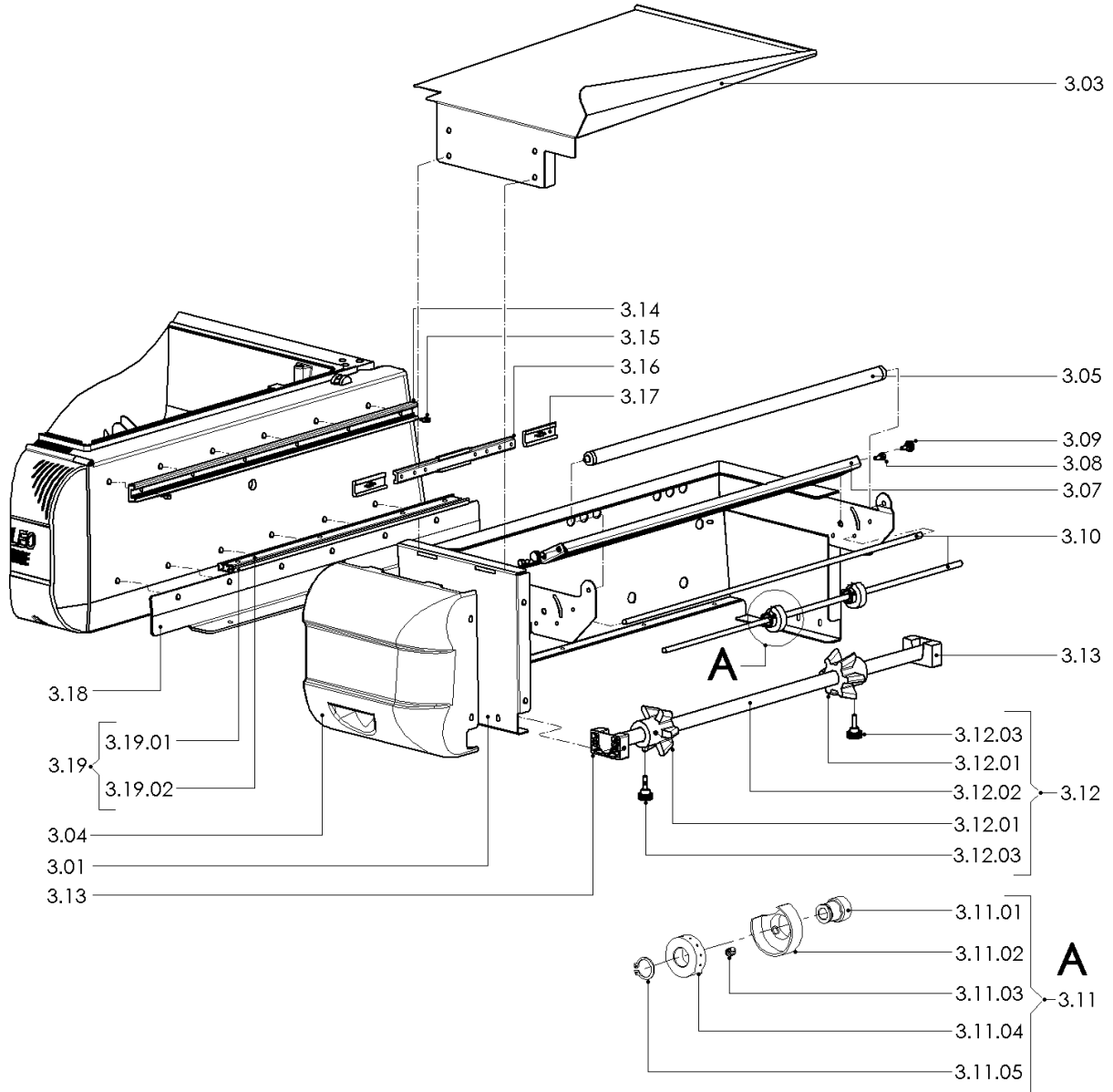

<b>ITEMS DESCRIPTION</b>	<b>SCHEME 4</b>
--------------------------	-----------------

<b>Pos.</b>	<b>Code</b>	<b>Description</b>
4.01	FM081010 FM081014	Fairing RAL2004B. Fairing RAL7035B.
4.02	FM200266	Pin x hinge
4.03	FM081011 FM081015	Front panel x fairing RAL2004B. Front panel x fairing RAL7035B.
4.04	FM090963	Lower cover
4.05	KR260001	Fan kit
4.05.01	FM830007	Fan
4.05.02	FM852404	Screw STEI M6X8
4.06	FE120263	Control board (valid from serial number 2843 dated 07.2009)
	FE120380 (old)	Control board (valid up to serial number 2842 dated 07.2009)
4.07	FE120605	Membrane keyboard (valid from serial number 2843 dated 07.2009)
	FM110300 (old)	Adhesive membrane x control board (valid up to serial number 2842 dated 07.2009)
4.08	FM230507	Small glass x display (valid up to serial number 2842 dated 07.2009)
4.09	FE080001	Main switch
4.10	FE120264	Power board 230V (valid from serial number 2843 dated 07.2009)
	FE120381 (old)	Power board 230V with fuses (valid up to serial number 2842 dated 07.2009)
	FE120388 (old)	Power board 230V with fuses (ETL version) (valid up to serial number 2842 dated 07.2009)
	FE120383	Power board 200V
4.10.01	FE290407	Fuse 10.3X38 AM 16A (230V)
	FE290701	Fuse 10.3X38 FNM 15A (230V ETL)
4.11	FE440616 FE440556	Transformer 2400VA 200-230V Transformer 700VA 230V (ETL version)
4.12	FE280005	Pump 230V (valid from serial number 558 dated 03.2006)
	FE280007	Pump 200V
4.13	FM090970	Pump support (valid from serial number 558 dated 03.2006)
4.14	FE310051	In-built socket
4.15	FE241020 FE241021	Single-phase motor 230V Single-phase motor 200V
4.16	FE260020 FE260022	Ventilator 230V Ventilator 200V
4.17	FM090982	Ventilator support (valid from serial number 680 dated 04.2006)

	<p><b>Machines from serial nr 2888 up to 2895 and from serial nr 2898 up to 2905 dated 10.2009 have been produced according to the previous configuration, that is with control board (code FE120380), adhesive membrane (code FM110300) and power board (code FE120381).</b></p>
---	---

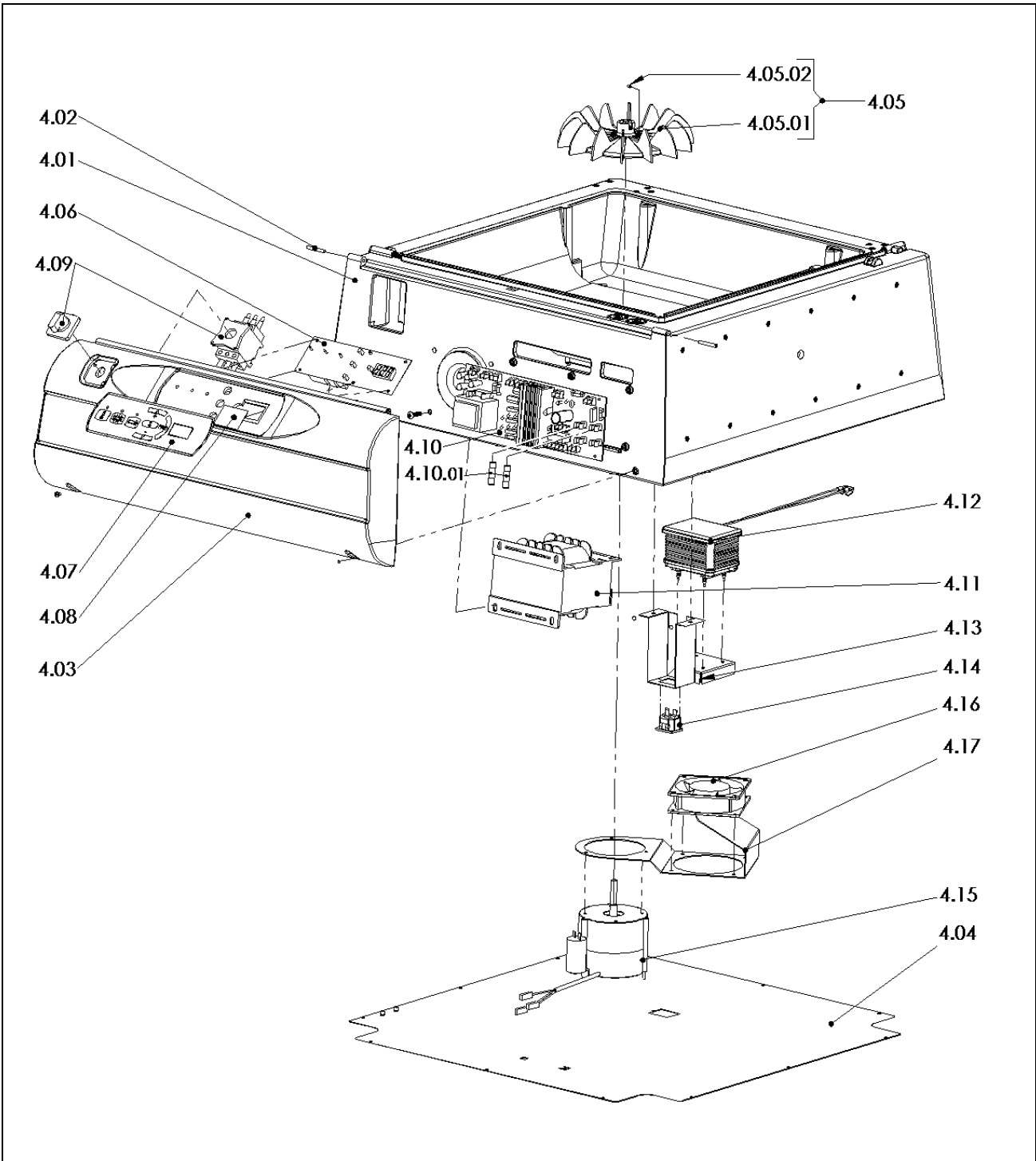

<b>ITEMS DESCRIPTION</b>	<b>SCHEME 5</b>
--------------------------	-----------------

<b>Pos.</b>	<b>Code</b>	<b>Description</b>
5.01	<b>CA26N001</b> <b>CA26I001</b>	Black trolley RAL9005B. Inox trolley.
5.01. 01	FM300214 FM300216	Support RAL9005B. Chromium-plated support
5.01. 02	FM040176	Upper flange RAL9005B.
5.01. 03	FM040177	Lower flange RAL9005B.
5.01. 04	FM770546	Wheel Ø60 with brake
5.01. 05	FM770545	Wheel Ø60

5.02	<b>AV260A01</b>	200-230V Rewinder group (optional)
5.03	FM160231	Film guiding ring
5.04	FM010041	Film rewinder shaft
5.05	FM160111	Washer
5.06	FE220105	Microswitch
5.07	FM290175	Rewinder support
5.08	FM160104	Ring nut
5.09	FM170161	Spring
5.10	FM120040	Movable flange
5.11	FM250128	Hub
5.12	FM120041	Fixed flange
5.13	FM280326	Plate
5.14	FM250074	Roller
5.15	FM030063	Rod
5.16	FM060027	Lever
5.17	FM290172	Lever support
5.18	FE190032	Switch
5.19	FM290107	Gearmotor support
5.20	FE250016	200-220V gearmotor
5.21	FM095138	Case
5.22	FM290525	Square
5.23	FE310121	Cable 3X0,75X1000

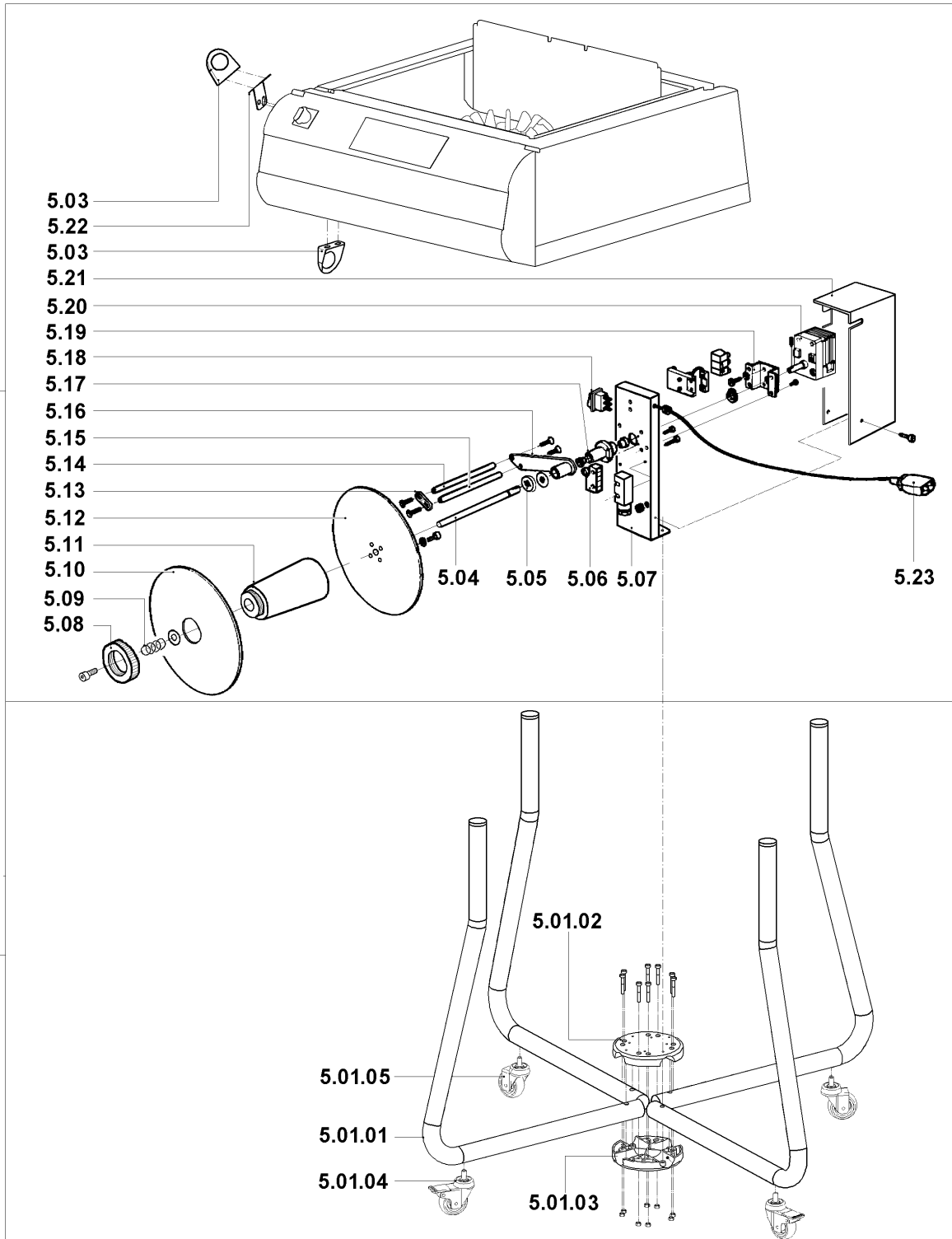

**WIRING DIAGRAM****SCHEME 6**

<i>B1</i>	<i>Cycle start limit switch</i>
<i>B2</i>	<i>Rewinder limit switch</i>
<i>BT1</i>	<i>Thermocouple</i>
<i>E1</i>	<i>Cooling fan</i>
<i>ER1</i>	<i>Sealing blade heater</i>
<i>ER2/3</i>	<i>Heaters</i>
<i>FU1/2</i>	<i>Line fuse 10.3X38</i>
<i>FU3</i>	<i>Card supplier fuse 5X20</i>
<i>FU4/5</i>	<i>Fan fuse 5X20</i>
<i>FU6/7</i>	<i>Ventilator fuse, cooling pump, rewinder 5X20</i>
<i>FU8</i>	<i>Magnet fuse 5X20</i>
<i>G1</i>	<i>Cooling pump</i>
<i>K1</i>	<i>Electronic control board</i>
<i>M1</i>	<i>Fan motor</i>
<i>M2</i>	<i>Rewinder motor</i>
<i>Q1</i>	<i>Main switch</i>
<i>Q2</i>	<i>Rewinder switch</i>
<i>SK1</i>	<i>Control board</i>
<i>T1</i>	<i>Cutting transformer</i>
<i>U1</i>	<i>Shrinking magnet</i>
<i>U2</i>	<i>Sealing magnet</i>
<i>X1</i>	<i>Rewinder power supply socket</i>
<i>X2</i>	<i>Rewinder power supply plug</i>

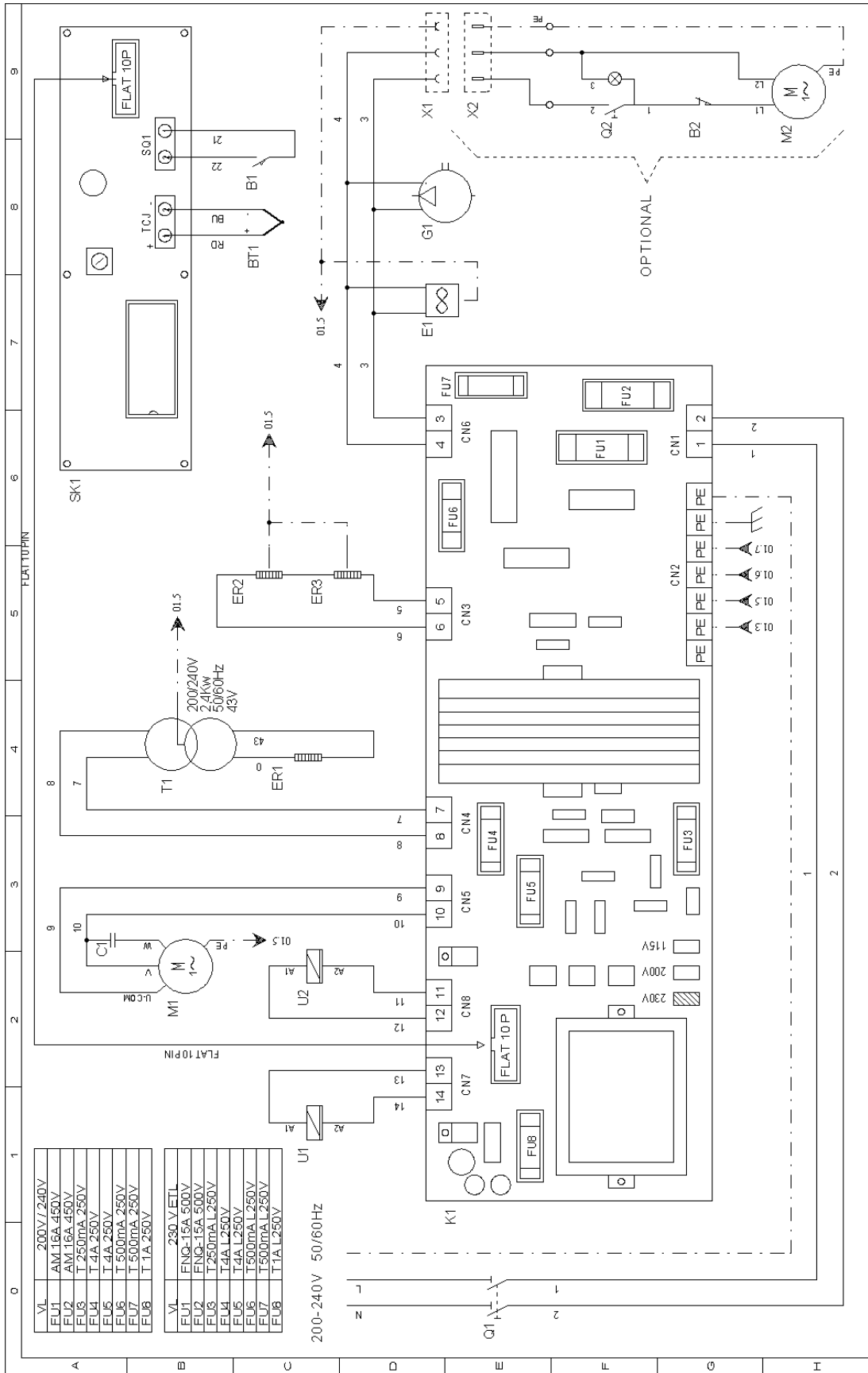

PROGETTO:	FOGLIO 01
CODICE:	DI 01
DISIGNO NR:	WDMF2601
TITOLO:	SCHEMA ELETTRICO
DISIGNATORE:	Baldori
DATA:	12.10.2005



***Minipack-torre S.p.A.***

*Via Provinciale, 54 - 24044 DALMINE (BG) - ITALY*

*Tel. (035) 563525 – Fax (035) 564945*

*E-mail: [info@minipack-torre.it](mailto:info@minipack-torre.it)*

*Internet: [www.minipack-torre.it](http://www.minipack-torre.it)*