



Minipack-torre S.p.A.

Via Provinciale, 54 - 24044 Dalmine (BG) - Italy

Tel. (035) 563525 – Fax (035) 564945

E-mail: info@minipack-torre.it

<http://www.minipack-torre.it>



Galaxy Classic Galaxy Office Galaxy Food

Spare parts catalogue

(Valid from serial number 1736 dated 03.2010 up to 1765 dated 04.2010 230V version)

(Valid from serial number 1736 dated 03.2010 up to 2144 dated 07.2011 120V version)

REV.02: new upper hood version.

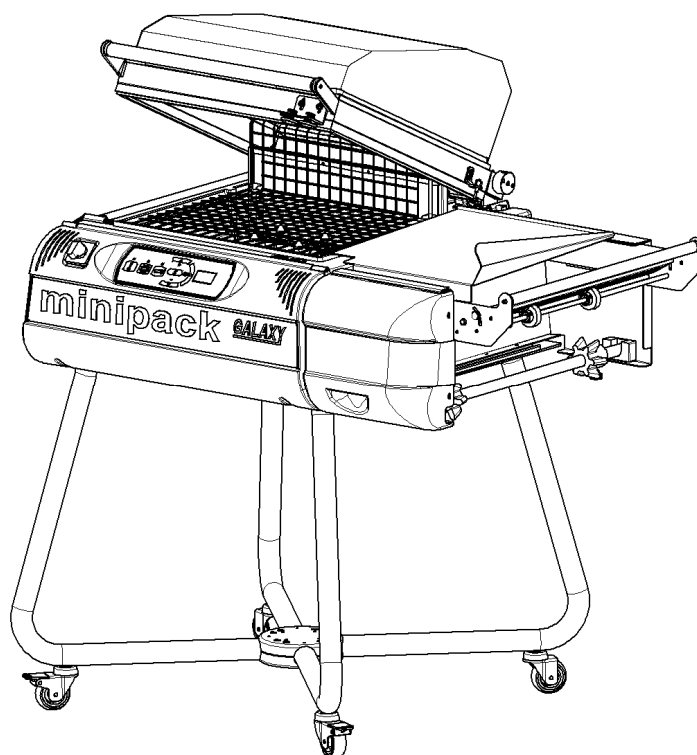

CAREFULLY READ THIS CATALOGUE BEFORE ORDERING ANY SPARE PART



DOC. N. FM112111
REV. 02
ED. 09.2011

ITEMS DESCRIPTION**SCHEME 1****Heating chambers****230V version:**

Valid from serial number 101 dated 10.2006 up to serial number 1482 dated 02.2009.

100V / 120V ETL version:

Valid from serial number 101 dated 10.2006 up to serial number 2144 dated 07.2011.



*Note: for the 230V version only, when replacing 1 of the 2 heaters, or both (pos. 1.10 and 1.11), please, order the spare part code nr. **KR280A10** (one unit).*

Pos.	Code	Description
1.01	P0K00309	Front and back terminal pre-assembly
1.01.01	FM650111	Gasket OR 2018
1.01.02	FM290522	Blade stretcher support
1.01.03	FM170178	Compression spring
1.01.04	FM850703	Screw TC M3X8
1.01.05	FM210017	Blade stretcher small piston
1.02	P0K00350	Central terminal pre-assembly
1.02.01	FM040191	Central terminal
1.02.02	FM650111	Gasket OR 2018
1.02.03	FM850703	Screw TC M3X8
1.03	FM340505	Plug x blade stretcher support
1.04	FM220625	Insulator holder section
1.05	FM050119	Blade holder insulator
1.06	FE385602	Sealing blade
1.07	FM130018	Reticulated plate
1.08	FM195109	Glass wool panel
1.09	FM090984	Front heater plate
1.10	KR280A10	(230V) Heat sink kit
	FE381153	Heater W1050 V71 (valid for 120V ETL)
	FE381155	Heater W1050 V62 (valid for 100V)
1.11	KR280A10	(230V) Heat sink kit
	FE381154	Heater with thermocouple W650 V44 (valid for 120V ETL)
	FE381156	Heater with thermocouple W650 V38 (valid for 100V)
1.12	FM090983	Back heater plate
1.13	FM090985	Right heating chamber cover
1.14	FM090986	Left heating chamber cover
1.16	FM195110	Insulating panel
1.17	FM281411	Heating chamber paddle
1.18	FM170179	Constrast spring
1.19	FM350604	Product support

Heating chambers

230V version:

Valid from serial number 101 dated 10.2006 up to serial number 1482 dated 02.2009.

100V / 120V ETL version:

Valid from serial number 101 dated 10.2006 up to serial number 2144 dated 07.2011.



*Note: for the 230V version only, when replacing 1 of the 2 heaters, or both (pos. 1.10 and 1.11), please, order the spare part code nr. **KR280A10** (one unit).*

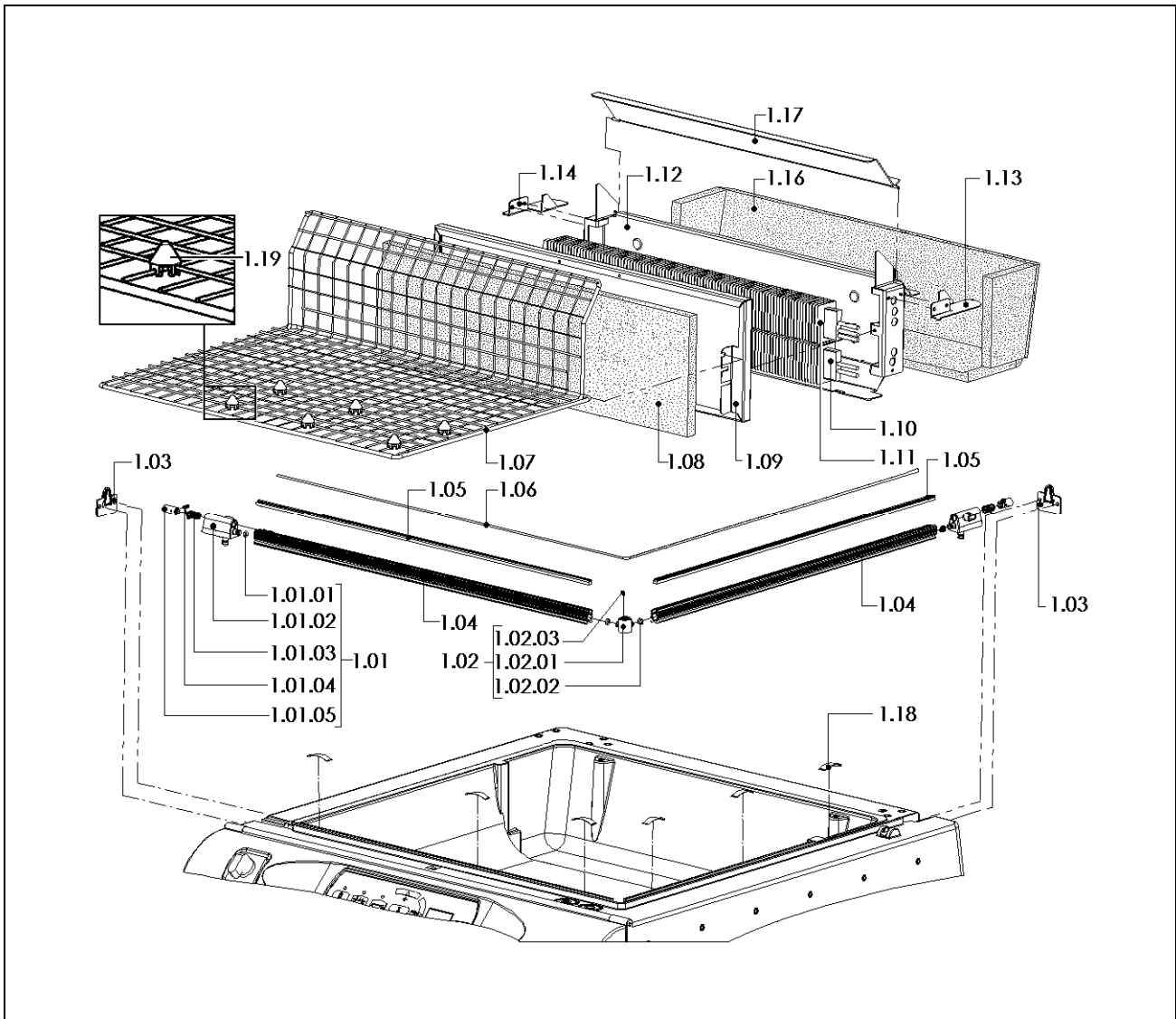

ITEMS DESCRIPTION**SCHEME 1.1****New style heating chambers****230V version:** Valid from serial number 1483 dated 02.2009.

Pos.	Code	Description
1.01	P0K00309	Front and back terminal pre-assembly
1.01.01	FM650111	Gasket OR 2018
1.01.02	FM290522	Blade stretcher support
1.01.03	FM170178	Compression spring
1.01.04	FM850703	Screw TC M3X8
1.01.05	FM210017	Blade stretcher small piston
1.02	P0K00350	Central terminal pre-assembly
1.02.01	FM040191	Central terminal
1.02.02	FM650111	Gasket OR 2018
1.02.03	FM850703	Screw TC M3X8
1.03	FM340505	Plug x blade stretcher support
1.04	FM220625	Insulator holder section
1.05	FM050119	Blade holder insulator
1.06	FE385602	Sealing blade
1.07	FM130018	Reticulated plate
1.08	FM195109	Glass wool panel
1.09	FM090984	Front heater plate
1.10	KR280A10	Kit dissipatore W1900 230V
1.10.01	FM390010	W1900 V230 Heat sink
1.10.02	S0K01210	Safety thermostat
1.10.03	FM435011	Thermocouple
1.12	FM091207	Back heater plate
1.13	FM090985	Right heating chamber cover
1.14	FM090986	Left heating chamber cover
1.16	FM195110	Insulating panel
1.17	FM281411	Heating chamber paddle
1.18	FM170179	Constrast spring
1.19	FM350604	Product support

New style heating chambers

230V version: Valid from serial number 1483 dated 02.2009.

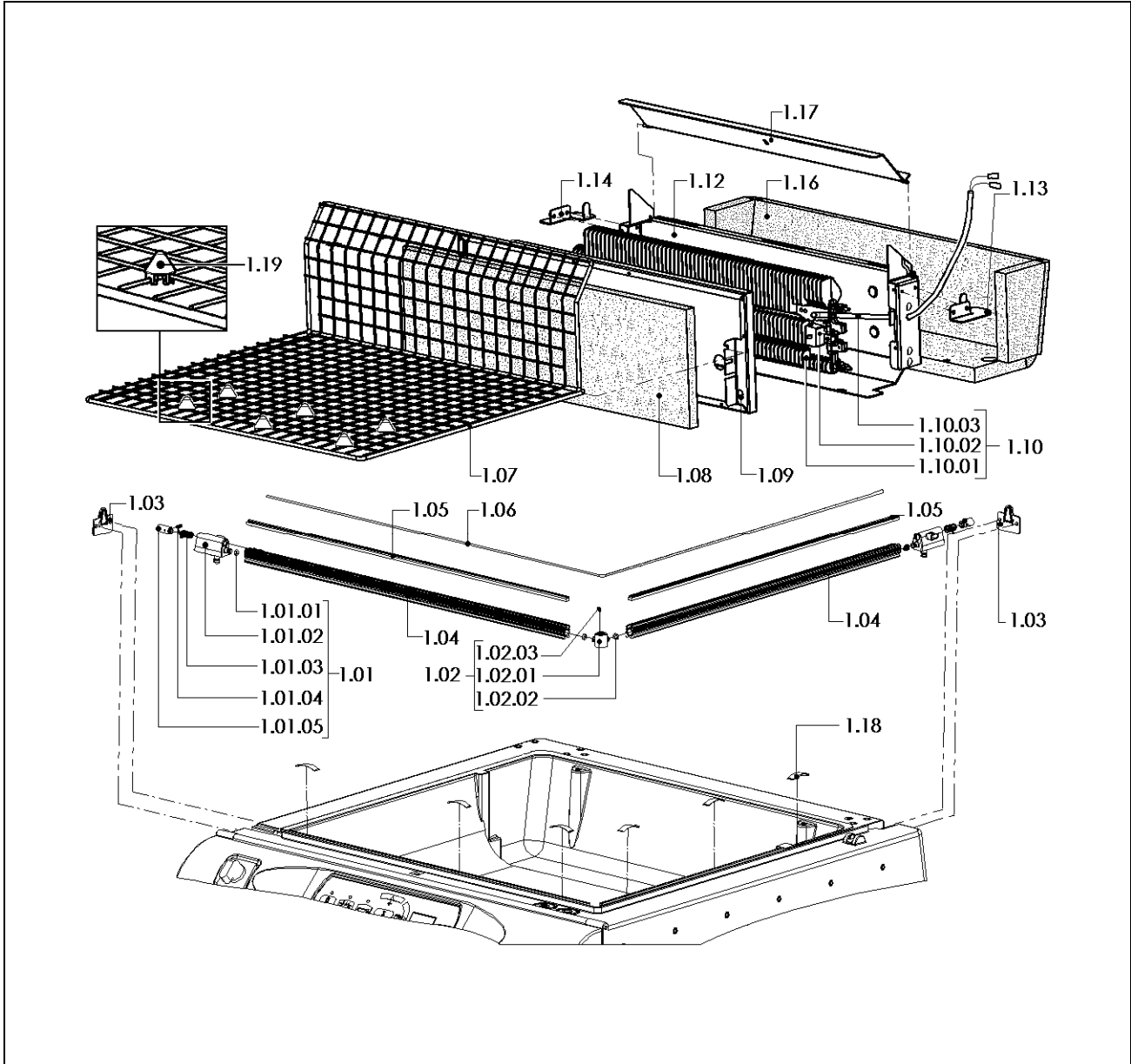

ITEMS DESCRIPTION	SCHEME 2
--------------------------	-----------------

Pos.	Code	Description
2.01	FM081041	Upper hood (valid from serial number 1736 dated 03.2010)
2.02	FM852207	M4X14 screw
2.04	FM300251	Frame for upper hood (valid from serial number 1736 dated 03.2010)
2.05	FM540007	Bush
2.06	KR260007	Tracer point kit x microswitch
2.06.01	FM160001	Ring nut x tracer point
2.06.02	FM290524	Square x tracer point
2.06.03	FM160224	Microswitch tracer point
2.06.04	FM850914	Screw TC+ M4X12
2.06.05	FM859002	Spring washer Ø4
2.07	KR260013	Paddle opening lever kit
2.07.01	FM281404	Paddle opening lever
2.07.02	FM850914	Screw TC+ M4X12
2.07.03	FM859002	Spring washer Ø4
2.07.04	FM858502	Flat washer Ø4
2.08	KR280009	Upper rubber holder section kit
2.08.01	FM220223	Front and back rubber holder section
2.08.02	FM220224	Side rubber holder section
2.09	KR280020	Handgrip kit x hood
2.09.01	FM150007	Handgrip
2.09.02	FM340005	Bush x handgrip
2.09.03	FM870101	Screw M6X15
2.10	FM290523	Electromagnet contrast support
2.11	FM170177	Compression spring
2.12	FM160026	Electromagnet contrast
2.13	FE130013	Elettromagnet
2.14	S0K01004	Torsion bar housing kit
2.14.01	FM020001	Torsion bar housing
2.14.02	FM851216	Screw TCEI M6X20
2.14.03	FM858504	Flat washer Ø6
2.14.04	FM850110	Screw TE M8X40
2.14.05	FM855805	Low nut M8
2.15	FM290101	Hood support
2.16	FM170009	Torsion bar (valid from s.n.1451 dated 10.2008)
	FM170007	Torsion bar (valid up to s.n.1450 dated 10.2008)
2.17	FM250104	Tube x torsion bar
2.18	S0K01005	Left pin kit x hood rotation
2.18.01	FM200094	Left pin x hood rotation
2.18.02	FM858507	Flat washer Ø12
2.18.03	FM855710	Nut M12X1,25
2.19	S0K01002	Right pin kit x hood rotation
2.19.01	FM200052	Right pin x hood rotation
2.19.02	FM858507	Flat washer Ø12
2.19.03	FM855710	Nut M12X1,25
2.20	G0K00011	Hood shock absorber kit
2.20.01	FM290001	Rubber washer holder bracket
2.20.02	FM350001	Shock absorber rubber washer
2.20.03	FM280304	Plate x bracket
2.20.04	FM851210	Screw TCEI M5X16
2.20.05	FM859003	Spring washer Ø5
2.21	S0K01001	Flange kit x torsion bar
2.21.01	FM120002	Flange x torsion bar
2.21.02	FM851213	Screw TCEI M6X14
2.21.03	FM850115	Screw TE M5X30
2.22	FM350025	Neoprene rubber 17X10 L.1900mm
2.23	KR280011	Upper hood teflon kit
2.23.01	FM240009	Teflon coating H.10mm L.570mm
2.24	S0K01208	Hood microswitch kit
	S0K01209	Hood microswitch kit (ETL version)
2.24.01	FE220137	Microswitch
	FE220127	Microswitch (ETL version)
2.24.02	FM280216	Plate x microswitch
2.24.03	FM850914	Screw TC+ M4X12

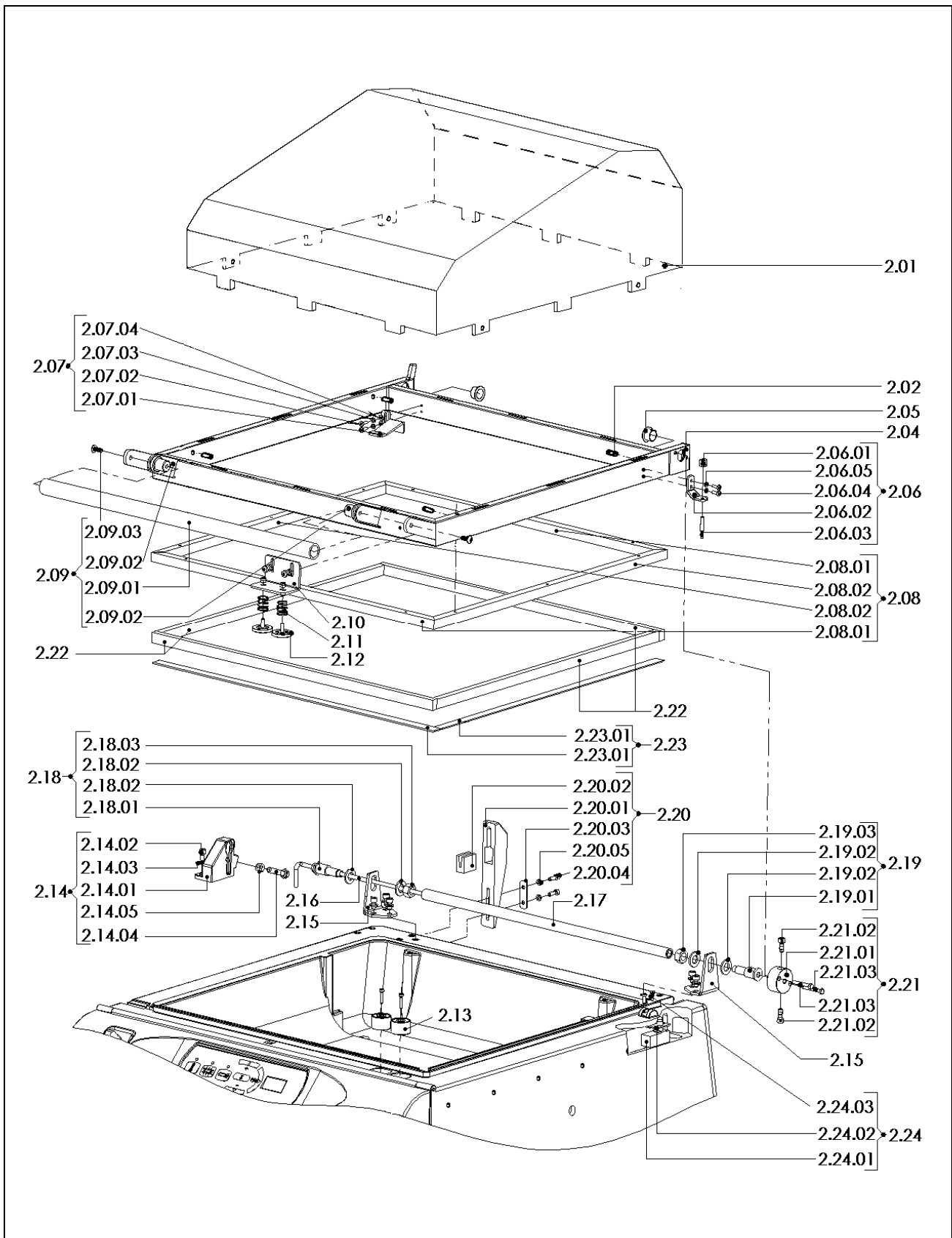

ITEMS DESCRIPTION	SCHEME 3
--------------------------	-----------------

Pos.	Code	Description
3.01	FM090756 FM090757	Reel support RAL2004L.. Reel support RAL7035L..
3.02	FM090857 FM090858 FM090859	Packaging plate RAL2004L.. Packaging plate RAL7035L.. Stainless steel packaging plate
3.04	FM081013 FM081016	Front panel x reel support RAL2004B.. Front panel x reel support RAL7035B..
3.05	FM710316	Transmission roller
3.07	FM095779	Micropuncher needle contrast
3.08	FM200267	Pin
3.09	FM510064	Handwheel M5X10
3.10	FM030163	Micropuncher rod
3.11	S0K00605	Small wheel kit with needles
3.11.01	FM340001	Bush
3.11.02	FM095137	Case
3.11.03	FM851803	Screw STEI M6X8
3.11.04	FM160007	Small wheel with needles
3.11.05	FM520005	Seeger for shafts Ø 14
3.12	KR280002	Reel holder roller kit
3.12.01	FM340010	Centering cone
3.12.02	FM250571	Reel holder roller
3.12.03	FM510065	Handwheel M6X20
3.13	FM340510	Support x reel holder roller
3.14	FM220629	Profile x guide
3.15	FM200265	Clamping pin
3.16	FM220626	Profile x internal guide
3.17	FM340506	Sliding block x internal guide profile
3.18	FM090989 FM090990	Square x guide RAL2004L.. Square x guide RAL7035L..
3.19	KR280003	Reel support guide kit
3.19.01	FM140036	Female guide
3.19.02	FM140037	Male guide

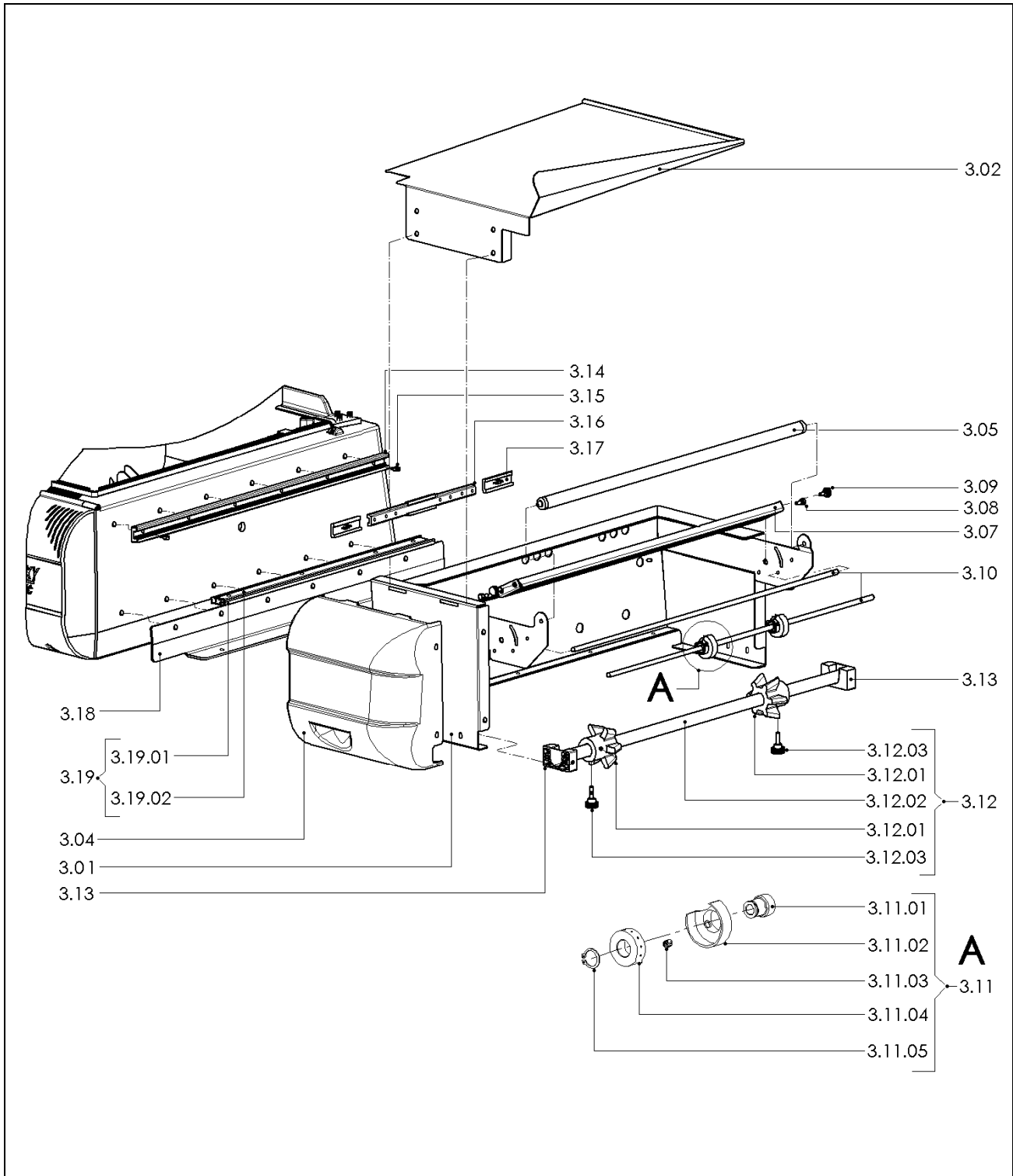

ITEMS DESCRIPTION	SCHEME 4
--------------------------	-----------------

Pos.	Code	Description
4.01	FM081022 FM081025	Fairing RAL2004B. Fairing RAL7035B.
4.02	FM200266	Pin x hinge
4.03	FM081023 FM081026	Front panel x fairing RAL2004B. Front panel x fairing RAL7035B.
4.04	FM090987	Lower cover
4.05	KR260001	Fan kit
4.05.01	FM830007	Fan
4.05.02	FM852404	Screw STEI M6X8
4.06	FE120263	Control board (valid from serial number 1596 dated 07.2009)
	FE120380 (old)	Control board (valid up to serial number 1595 dated 07.2009)
4.07	FE120605	Membrane keyboard (valid from serial number 1596 dated 07.2009)
	FM110300 (old)	Adhesive membrane x control board (valid up to serial number 1595 dated 07.2009)
4.08	FM230507	Small glass x display (valid up to serial number 1595 dated 07.2009)
4.09	FE080001 FE080000	Main switch 230V Main switch 100-120V ETL
4.10	FE120264	Power board 230V (valid from serial number 1596 dated 07.2009)
	FE120381 (old)	Power board 230V with fuses (valid up to serial number 1595 dated 07.2009)
	FE120389	Power board 100V
	FE120382	Power board 120V ETL with fuses
4.10.01	FE290407 FE290704	Fuse 10.3X38 AM 16A (230V) Fuse 10.3X38 FNQ 25A (120V ETL)
4.11	FE440747 FE440748 FE440552	Transformer 2000VA 230V Transformer 2000VA 100V Transformer 600VA 120V ETL
4.12	FE280005 FE280006	Pump 230V Pump 110-120V ETL
4.13	FM090970	Pump support
4.14	FE310051	In-built socket
4.15	FE241020 FE241022	Single-phase motor 230V Single-phase motor 100-120V ETL
4.16	FE260020 FE260021	Ventilator 230V Ventilator 100-120V ETL
4.17	FM090982	Ventilator support

	<p style="color: red;">Machines from serial nr 1626 up to 1650 dated 10.2009 have been produced according to the previous configuration, that is with control board (code FE120380), adhesive membrane (code FM110300) and power board (code FE120381).</p>
---	---

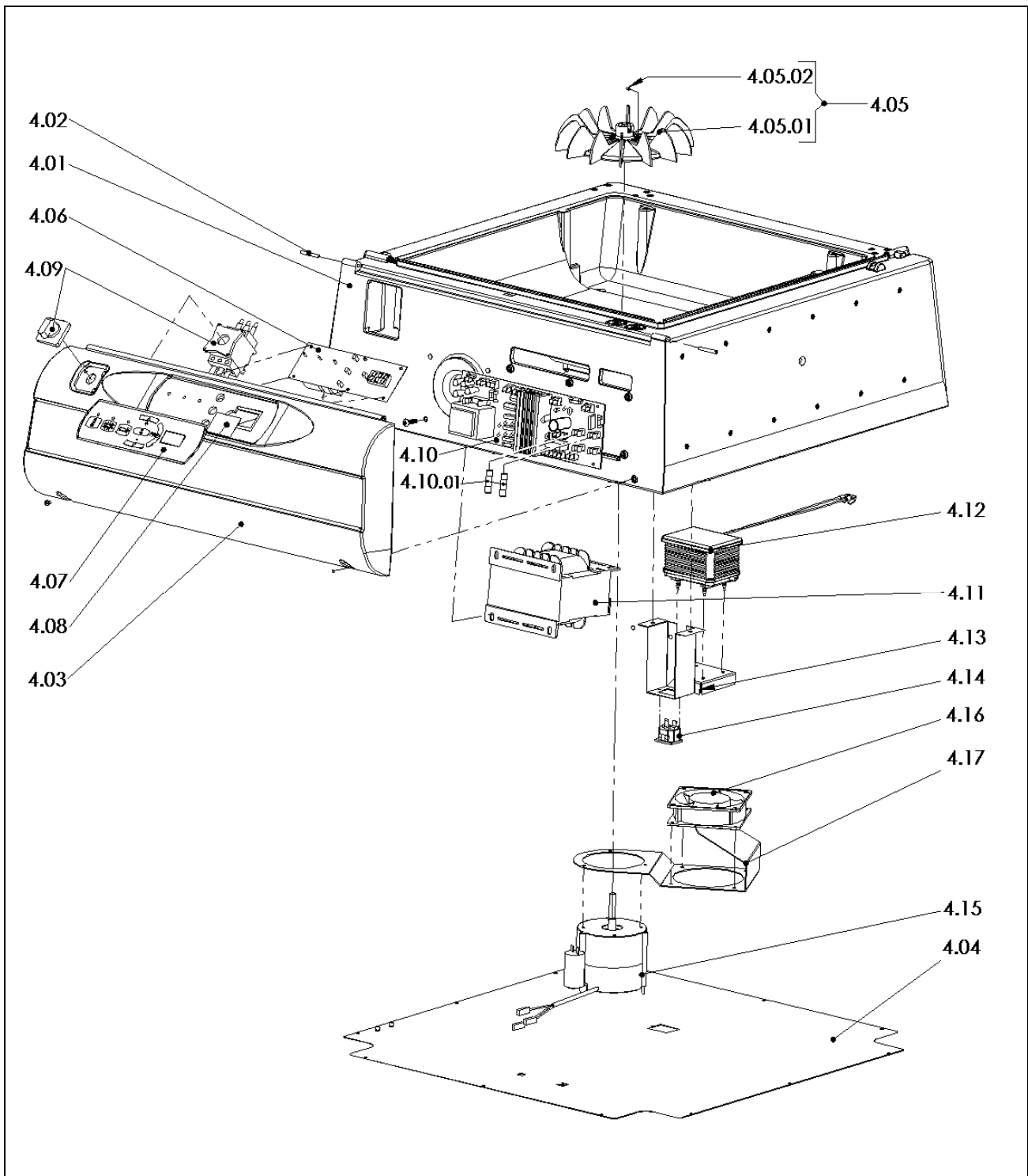

ITEMS DESCRIPTION	SCHEME 5
--------------------------	-----------------

Pos.	Code	Description
5.01	CA28N001 CA28I001	Black trolley RAL9005B. Inox trolley.
5.01. 01	FM300234 FM300235	Support RAL9005B. Chromium-plated support
5.01. 02	FM040176	Upper flange RAL9005B.
5.01. 03	FM040177	Lower flange RAL9005B.
5.01. 04	FM770546	Wheel Ø60 with brake
5.01. 05	FM770545	Wheel Ø60

5.02	AV260A01 AV260E01	230V Rewinder group (optional) 120V Rewinder group (optional)
5.03	FM160231	Film guiding ring
5.04	FM010041	Film rewinder shaft
5.05	FM160111	Washer
5.06	FE220105	Microswitch
5.07	FM290175	Rewinder support
5.08	FM160104	Ring nut
5.09	FM170161	Spring
5.10	FM120040	Movable flange
5.11	FM250128	Hub
5.12	FM120041	Fixed flange
5.13	FM280326	Plate
5.14	FM250074	Roller
5.15	FM030063	Rod
5.16	FM060027	Lever
5.17	FM290172	Lever support
5.18	FE190032	Switch
5.19	FM290107	Gearmotor support
5.20	FE250016 FE250017	200-220V gearmotor 120V gearmotor
5.21	FM095138	Case
5.22	FM290525	Square
5.23	FE310121	Cable 3X0,75X1000

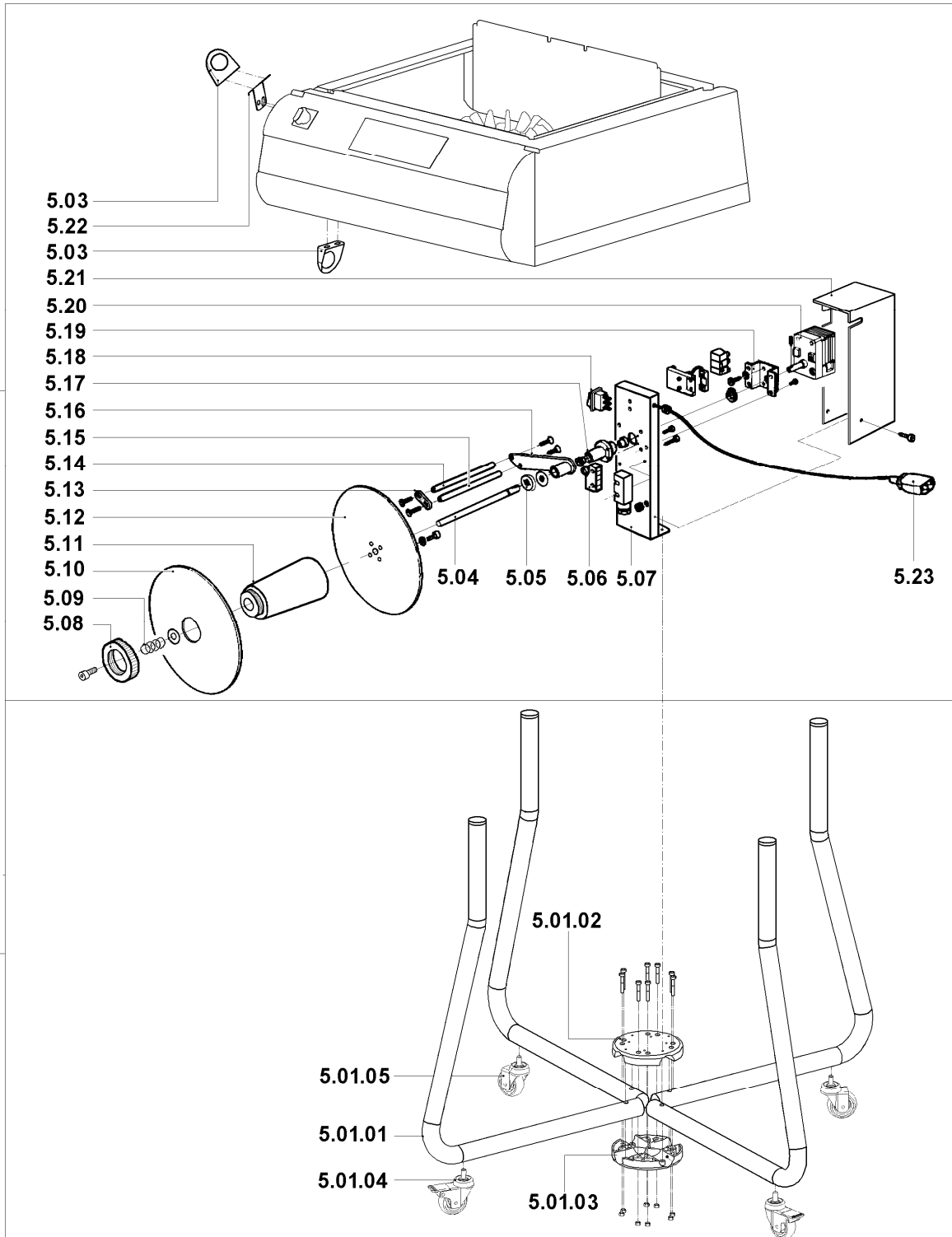

<i>B1</i>	<i>Cycle start limit switch</i>
<i>B2</i>	<i>Rewinder limit switch</i>
<i>BT1</i>	<i>Thermocouple</i>
<i>E1</i>	<i>Cooling fan</i>
<i>ER1</i>	<i>Sealing blade heater</i>
<i>ER2/3</i>	<i>Heaters</i>
<i>FU1/2</i>	<i>Line fuse 10.3X38</i>
<i>FU3</i>	<i>Card supplier fuse 5X20</i>
<i>FU4/5</i>	<i>Fan fuse 5X20</i>
<i>FU6/7</i>	<i>Ventilator fuse, cooling pump, rewinder 5X20</i>
<i>FU8</i>	<i>Magnet fuse 5X20</i>
<i>G1</i>	<i>Cooling pump</i>
<i>K1</i>	<i>Electronic control board</i>
<i>M1</i>	<i>Fan motor</i>
<i>M2</i>	<i>Rewinder motor</i>
<i>Q1</i>	<i>Main switch</i>
<i>Q2</i>	<i>Rewinder switch</i>
<i>SK1</i>	<i>Control board</i>
<i>T1</i>	<i>Cutting transformer</i>
<i>U1</i>	<i>Shrinking magnet</i>
<i>U2</i>	<i>Sealing magnet</i>
<i>X1</i>	<i>Rewinder power supply socket</i>
<i>X2</i>	<i>Rewinder power supply plug</i>

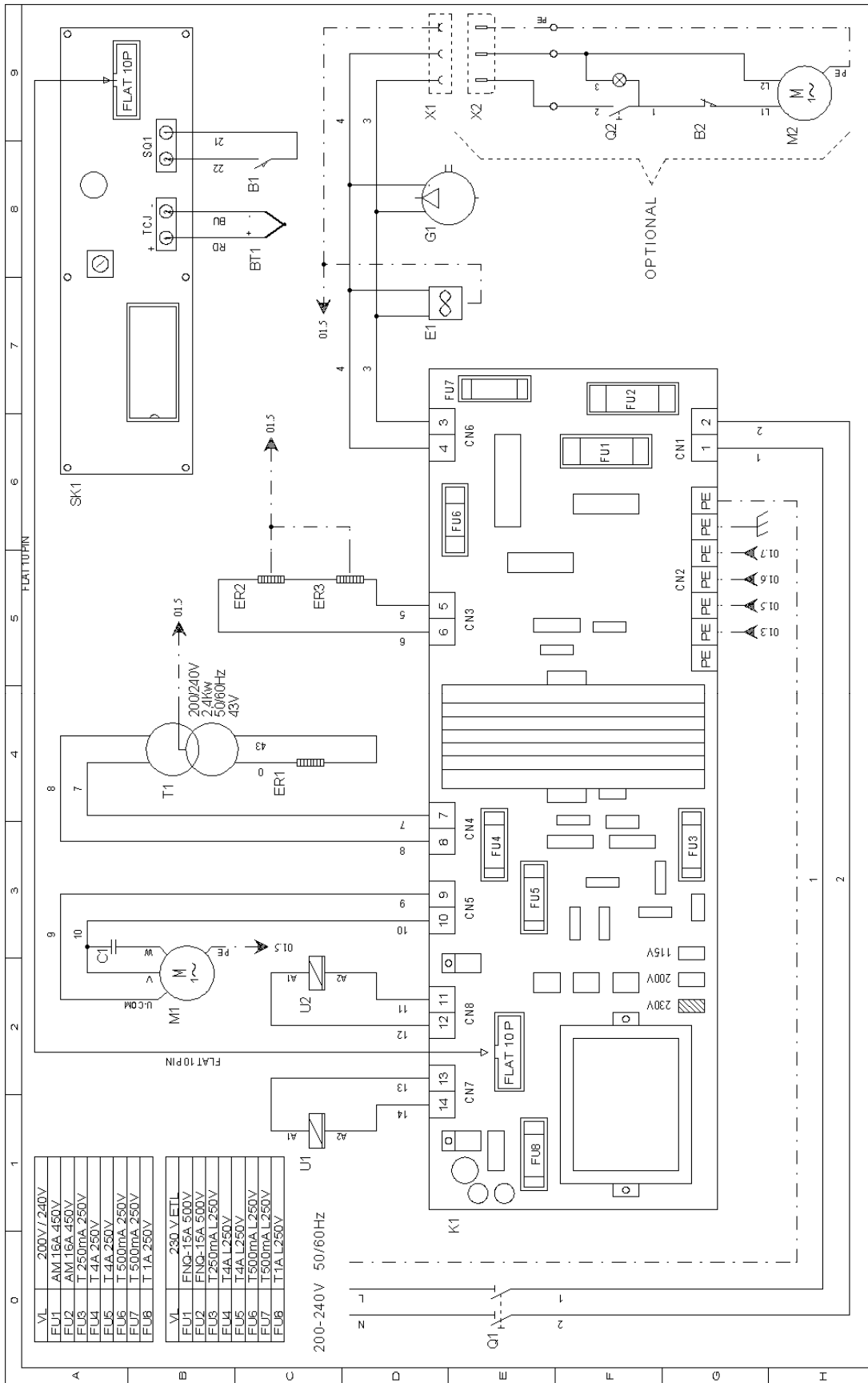

PROGETTO:	FOGLIO 01		
CODICE:	DI 01		
DISEGNO NR: WDMF2601			
TITOLO: SCHEMA ELETTRICO			
DISEGNATORE: Bidleri	DATA: 12.10.2005		
REV	DATA	FIRMA	MODIFICA

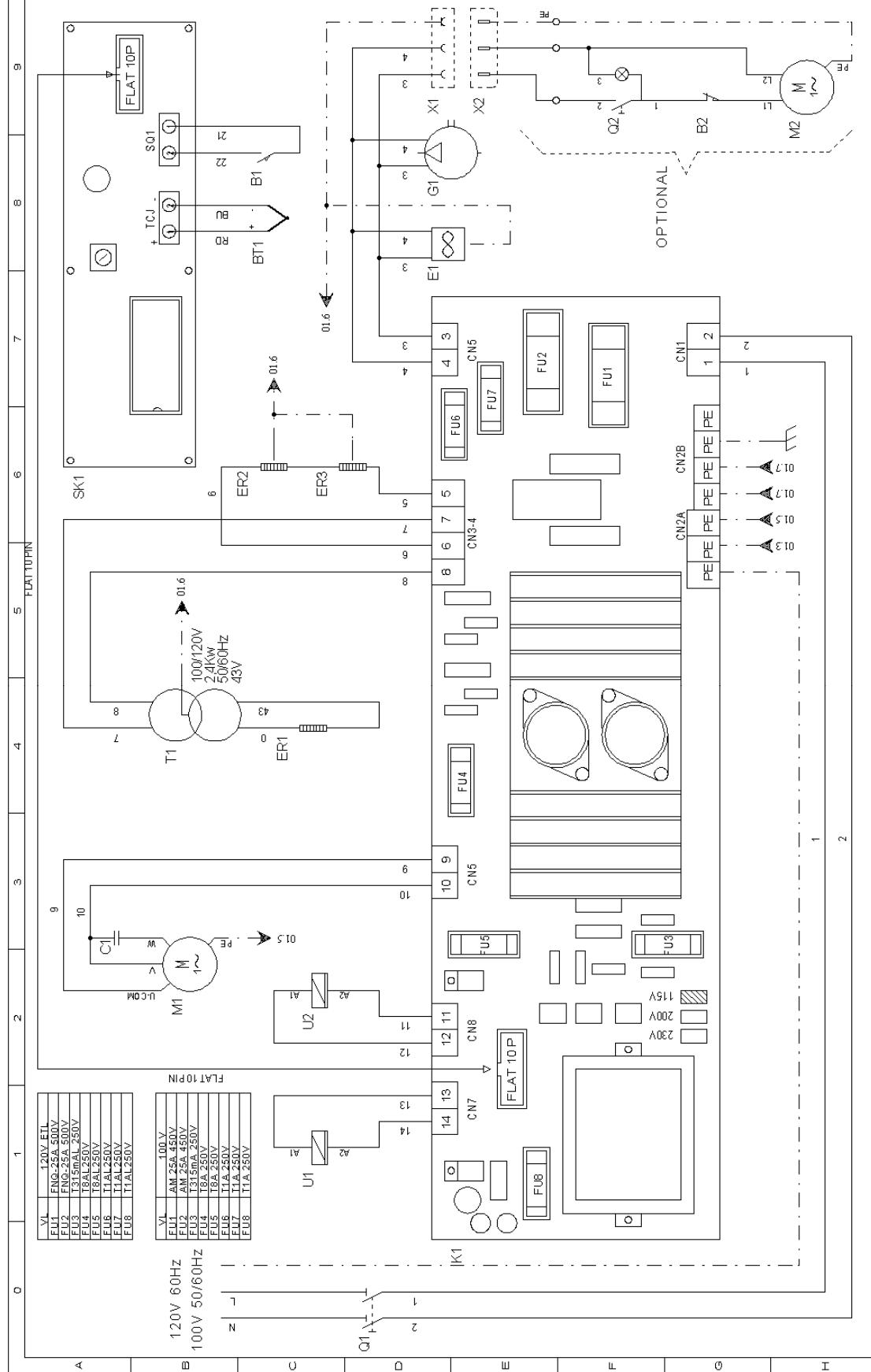

VL	120V ETL
FU1	FNQ-25A 500V
FU2	FNQ-25A 500V
FU3	I315MAL 250V
FU4	I8AL 250V
FU5	I16AL 250V
FU6	I11AL 250V
FU7	I11AL 250V
FU8	I11AL 250V

VL	100V
FU1	AM 25A 450V
FU2	AM 25A 450V
FU3	I315MA 250V
FU4	I8A 250V
FU5	I8A 250V
FU6	I11A 250V
FU7	I11A 250V
FU8	I11A 250V

PROGETTO:	GALAXY	FOGLIO	01
CODICE:		DI	01
DISIGNO NR:	WDMF2802	TITOLO:	SCHEMA ELETTRICO
DISIGNATORE:	Baldoni	DATA:	12/06/2007
REV.	DATA	FIRMA	MODIFICA



Minipack-torre S.p.A.

Via Provinciale, 54 - 24044 DALMINE (BG) - ITALY

Tel. (035) 563525 – Fax (035) 564945

E-mail: info@minipack-torre.it

Internet: www.minipack-torre.it