



**Minipack-torre S.p.A.**  
Via Provinciale, 54 - 24044 Dalmine (BG) - Italy  
Tel. (035) 563525  
E-mail: [info@minipack.it](mailto:info@minipack.it)  
<http://www.minipack.it>



# Modular 70 Digit Restyling

## Spare parts catalogue

(Valid from serial number 1805127 dated 12.2018)

REV.03: new safety microswitch



CAREFULLY READ THIS CATALOGUE BEFORE ORDERING ANY SPARE PART



DOC. N. FM112020  
REV. 03  
Ed: 12.2022

**ITEMS DESCRIPTION****SCHEME 1**

<b>Pos.</b>	<b>Code</b>	<b>Description</b>
1.02	S0K00303	Front clamp kit
1.03	S0K00304	Rear clamp kit
1.04	S03A0306	Blade holder central clamp kit
1.06	S03A0310	Infill blocks kit
1.07	S03A0319	Infill holder channel kit
1.08	S03A0901	Front guard kit
1.09	S03A0903	Side guard kit
1.10	KR030001	Teflon-coated sealing blade

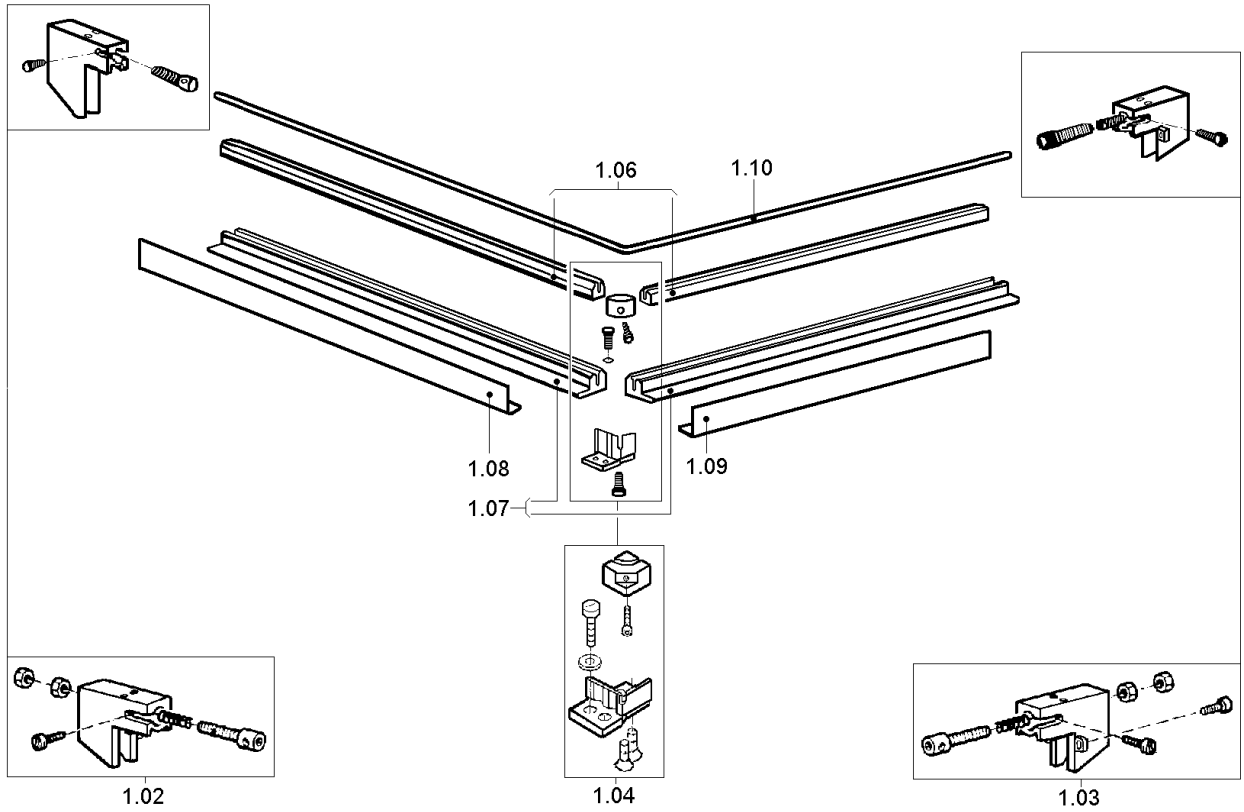

**ITEMS DESCRIPTION****SCHEME 2**

<b>Pos.</b>	<b>Code</b>	<b>Description</b>
2.00	FM090666	Central lower cover
2.01	FM090665	Right lower cover
2.02	FM090671	Left lower cover
2.03	FM095789	RAL7035B. machine left support
2.04	FM095896	RAL7035B. machine right support
2.05	PC03G001	RAL7035B. packaging plate kit
	PC03I000	Inox packaging plate kit (optional)
2.05.01	FM090357	RAL7035B. packaging plate
	FM091294	Inox packaging plate (optional)
2.05.02	FM300003	Packaging plate frame
2.06	FM095895	RAL7035B. fairing
2.07	FM770511	Wheel Ø100
2.08	FM770512	Wheel Ø100 with brake
2.09	KR130002	Blades internal protections kit
2.11	S0095580	RAL7035B. push button panel
2.12	S0190020	Panel + electronic board
2.12.01	SM190016	Panel
2.12.02	FM110226	Adhesive membrane x electronic board
2.12.03	FE120339	Electronic board
2.13	FE080001	Switch 20A
2.14	FM090039	RAL9005B. command panel
2.15	FM095195	Carter
2.16	FM140001	"ROLLGE 150" channel
2.17	FM220501	Guide corner
2.18	FE340501	Contacts holder
2.19	FE340506	"NC" contact
2.20	FE340505	"NO" contact
2.21	FE340005	Emergency pushbutton
2.22	FE340001	Start button
2.23	FE085004	MAN-AUT Selector

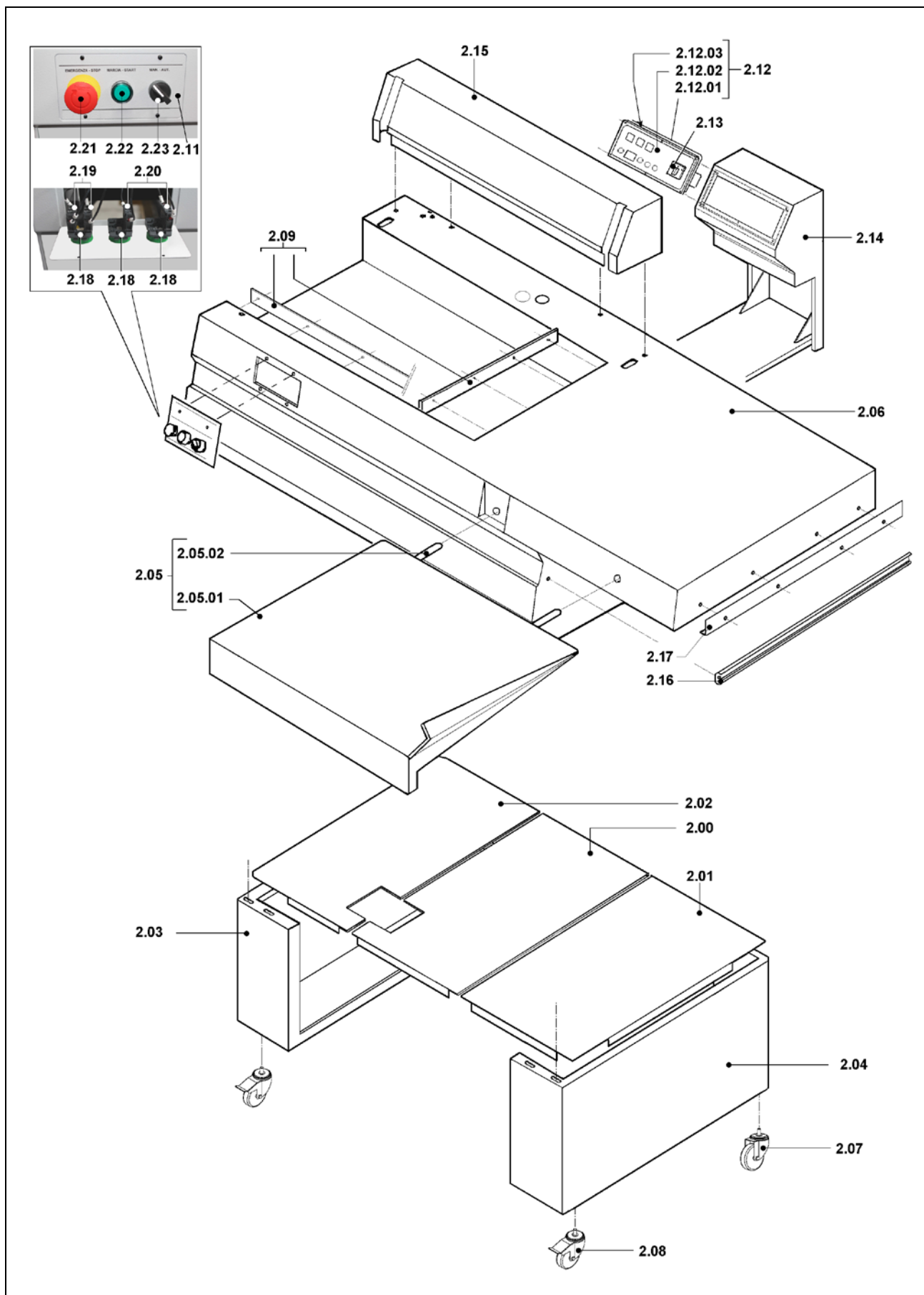

**ITEMS DESCRIPTION****SCHEME 3**

<b>Pos.</b>	<b>Code</b>	<b>Description</b>
3.01	PB13B004	RAL7035B. film roll support kit
3.02	S03A0602	Film roll tube kit
3.03	S03A0607	Microperforator rods kit
3.04	FM660002	Wheeled trolley
3.05	FM220501	Guide corner
3.06	FM090364	RAL7035B. film roll support
3.07	S03A0605	Microperforator with needles kit
3.08	S03A0606	Slotted microperforator kit
3.08.01	S0K00610	Rubber rings kit for wheel (10 pcs)
3.09	FM710318	Film drive roller

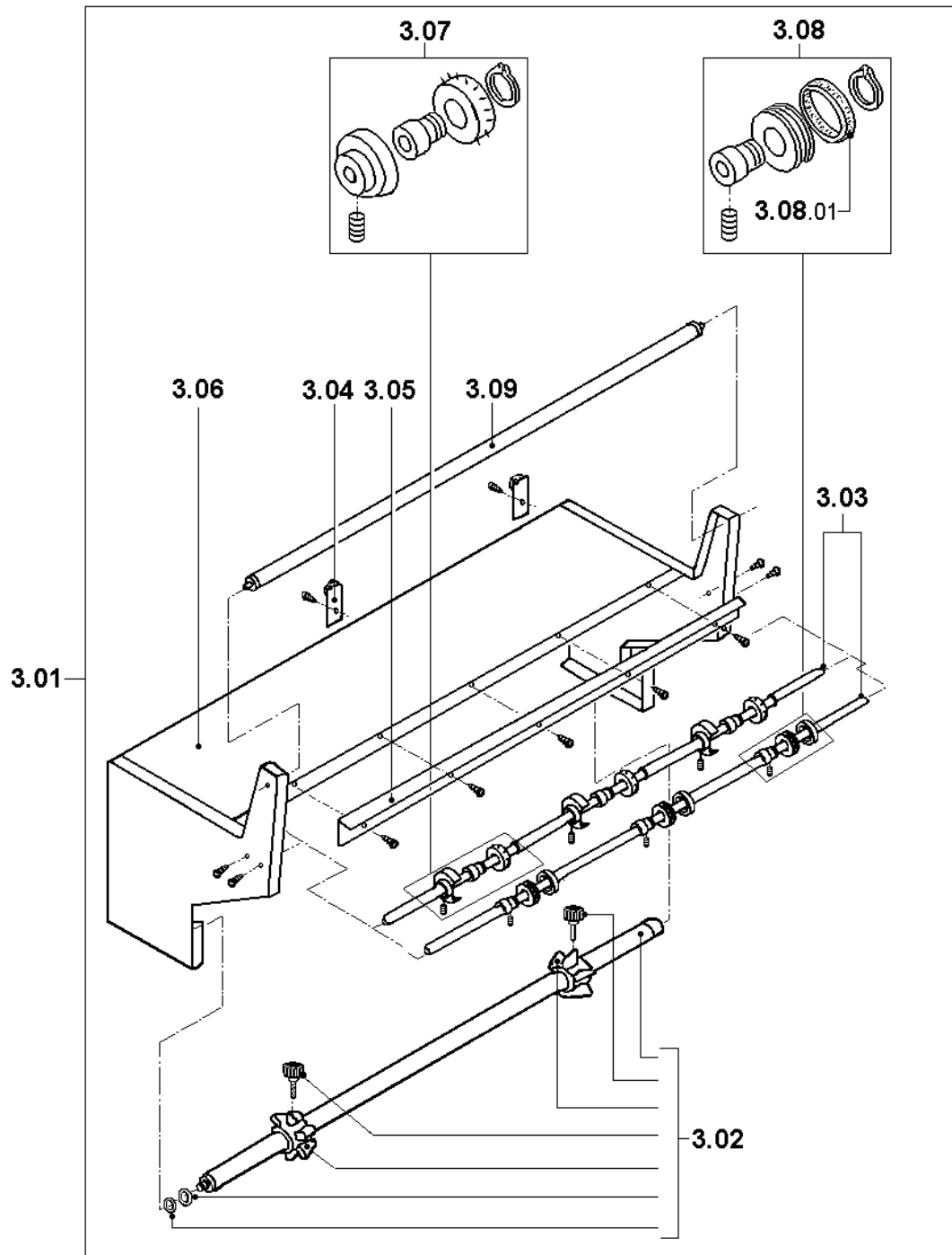

**ITEMS DESCRIPTION****SCHEME 4**

<b>Pos.</b>	<b>Code</b>	<b>Description</b>
4.01	S0K01001	Torsion bar blocking flange kit
4.02	FM540007	Bush
4.03	FE220133	Microswitch
4.04	FM060024	Security lever
4.05	S0K01002	Hood rotation right pin kit
4.06	FM200051	Pin
4.07	FM640002	Rod end
4.08	FM170135	Spring
4.09	FM160055	Lever blocking device
4.10	FM290101	Hood support
4.11	KR030002	Teflon kit
4.12	S0130405	Upper rubber holder channels kit
4.13	FM350024	White silicone rubber Lg.1550
4.14	FM300034	Frame
4.15	FM200093	Spacer
4.16	FM170117	Spring
4.17	FM290238	Support
4.18	S0K00412	Microswitch screw kit
4.20	S03A1003	Torsion bar housing kit
4.21	FM340100	Torsion bar bush
4.22	FM170003	Torsion bar
4.23	FM250103	Tube x torsion bar
4.24	FE220136	Microswitch

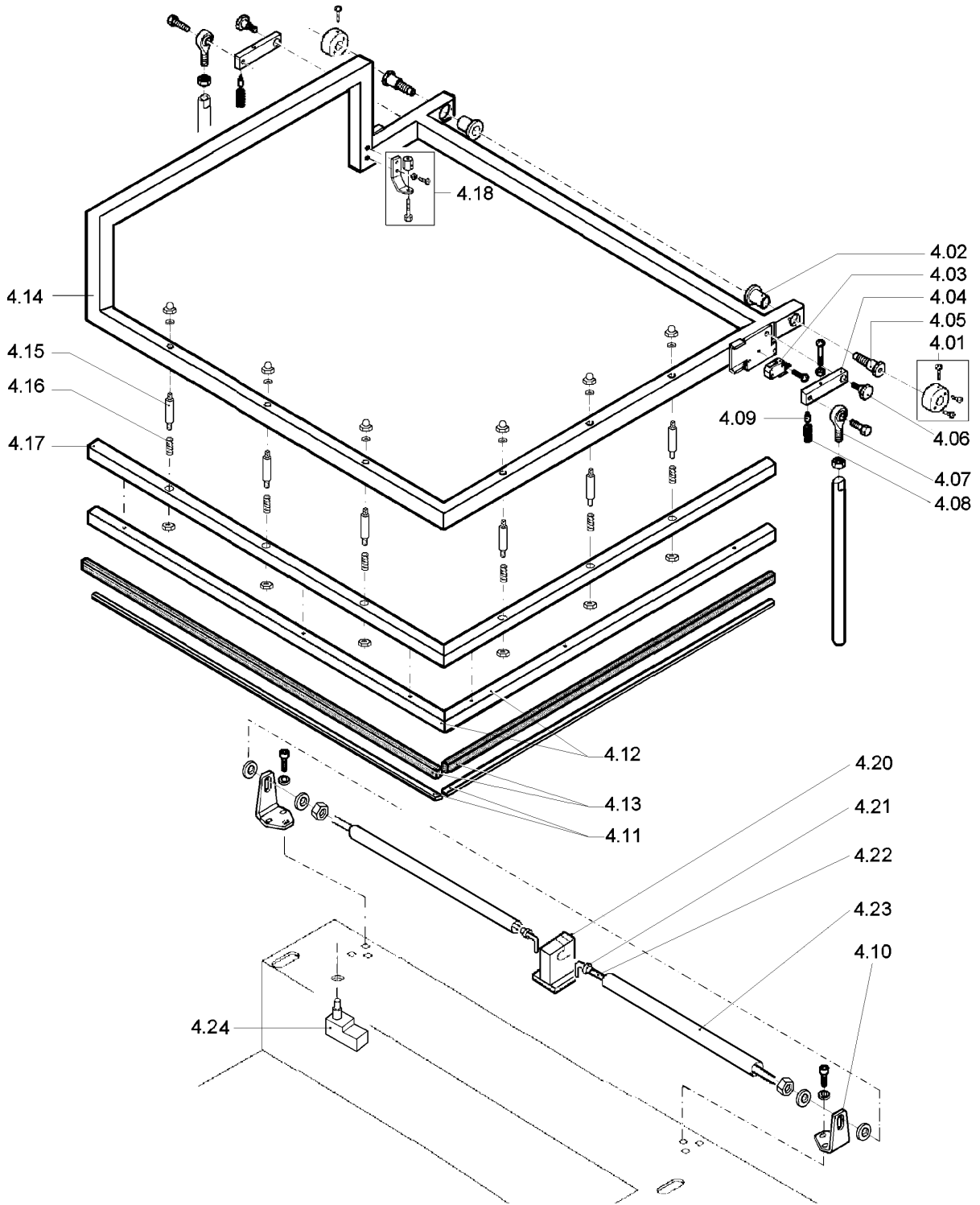

**ITEMS DESCRIPTION****SCHEME 5**

Old rewriter: valid up to s.n. **xxxxxx**

<b>Pos.</b>	<b>Code</b>	<b>Description</b>
5.01	AV130003	Rewinder group
5.02	FM300141	Crosspiece
5.03	FE190032	Switch
5.04	FM010041	Shaft
5.05	FM160111	Washer
5.06	FE220105	Microswitch
5.07	FM290175	Rewinder support
5.08	FM160104	Ring nut
5.09	FM170161	Spring
5.10	FM120040	Movable flange
5.11	FM250128	Hub
5.12	FM120041	Fixed flange
5.13	FM280326	Plate
5.14	FM250074	Roller
5.15	FM030063	Rod
5.16	FM060027	Lever
5.17	FM290172	Lever support
5.18	FE220101	Microswitch guard
5.19	FM290107	Gearmotor support
5.20	FE250015	Gearmotor
5.21	FM095138	Case
5.22	FM290258	Film transmission support
5.23	FM200069	Pin
5.24	FM250049	Transmission roller
5.25	S0K00407	Film guide kit
5.26	FE310122	Cable 3x0,75x1500
5.27	FM160231	Film guiding ring

Old rewinder: valid up to s.n. xxxxxx

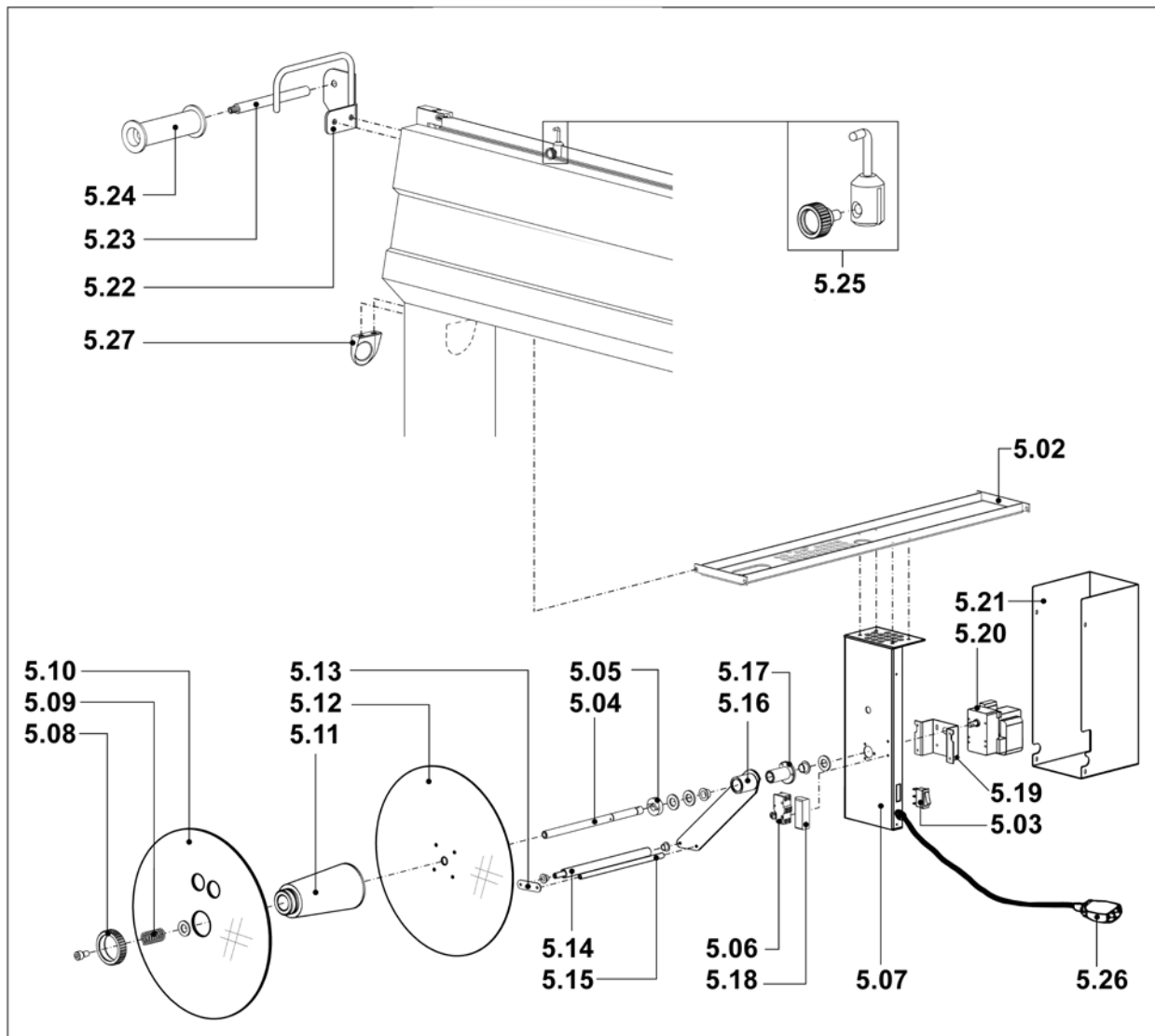

**ITEMS DESCRIPTION****SCHEME 5.1****New rewinder:** valid from s.n. **xxxxxx**

<b>Pos.</b>	<b>Code</b>	<b>Description</b>
5.01	AV130003	Rewinder group
5.02	FM300141	Crosspiece
5.03	FE190032	Switch
5.04	FM010001	Shaft
5.05	FM160111	Washer
5.06	FE220105	Microswitch
5.07	FM090211	Motor case
5.08	FM160104	Ring nut
5.09	FM170161	Spring
5.10	FM120040	Movable flange
5.11	FM250128	Hub
5.12	FM120041	Fixed flange
5.13	FM280326	Plate
5.14	FM250074	Roller
5.15	FM030063	Rod
5.16	FM060027	Lever
5.17	FM290172	Lever support
5.18	FE220101	Microswitch guard
5.19	FM291403	Plate
5.20	FE250016	Gearmotor
5.21	FM096519	Case
5.22	FM290258	Film transmission support
5.23	FM200069	Pin
5.24	FM250049	Transmission roller
5.25	S0K00407	Film guide kit
5.26	FE310122	Cable 3x0,75x1500
5.27	FM160231	Film guiding ring

New rewinder: valid from s.n. xxxxxx

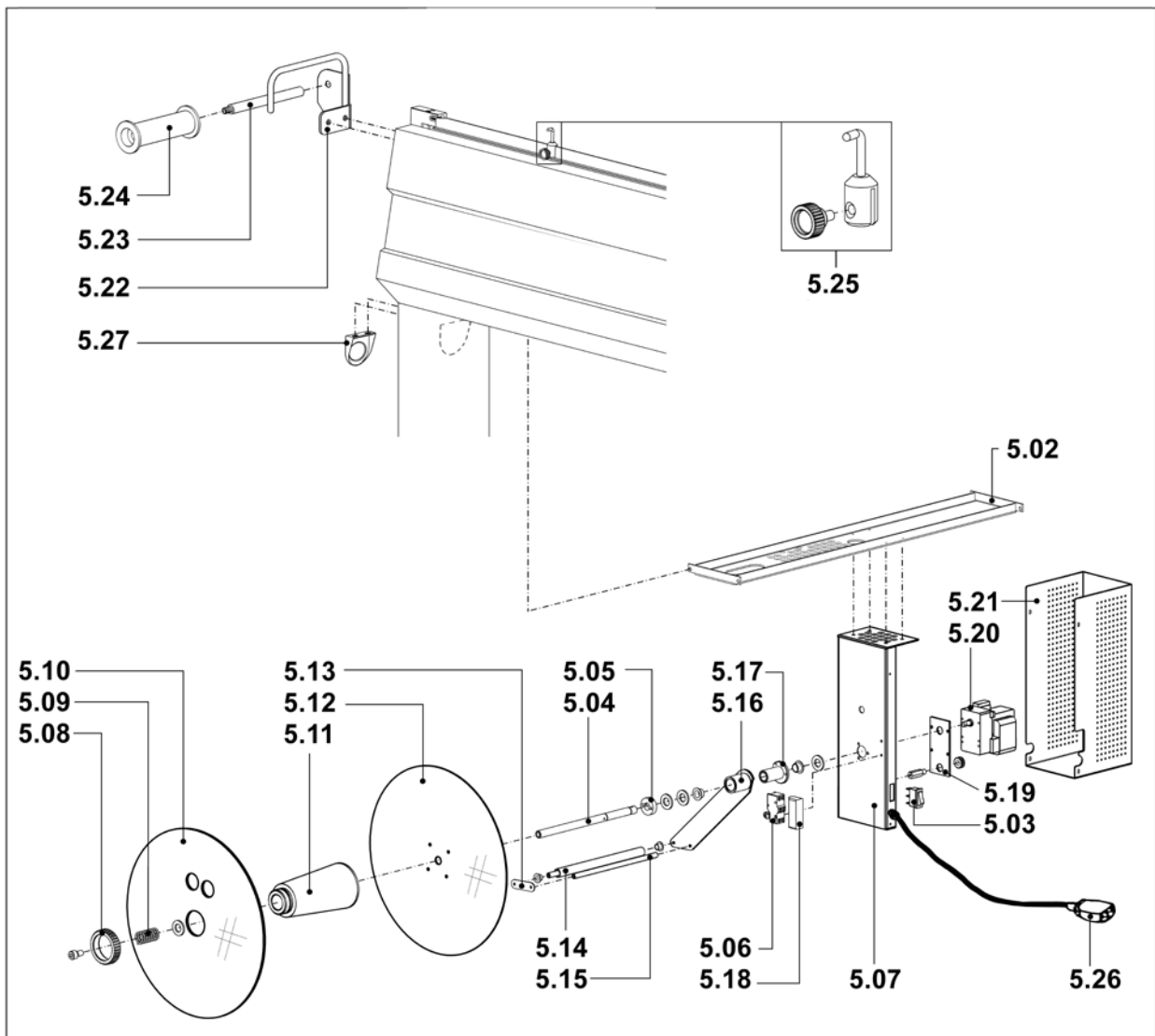

**ITEMS DESCRIPTION****SCHEME 6**

<b>Pos.</b>	<b>Code</b>	<b>Description</b>
6.01	NT130002	Transport belt kit
6.01.01	S0130023	Transmission roller kit
6.01.02	S0130022	Transmission roller kit
6.01.03	FM710112	Conveyor belt
6.01.04	FM200025	Adjusting screw
6.01.05	FM200026	Adjusting screw
6.01.06	FM095116	Case
6.01.07	FM710304	Transmission roller
6.01.08	FM090403	Sliding plane
6.01.09	FM280313	Gearmotor support plate
6.01.11	FM040008	Tensioning brake
6.01.12	FM300172	Belt frame
6.01.13	FE250043	Gearmotor
6.01.14	FM260022	Pinion
6.01.15	SM100001+	Chain
	FM550006	Joint
6.01.16	FM040005	Adjusting brake
6.01.17	FM160056	Specer
6.01.20	FM290130	Front support
6.01.21	FM610022	Radial bearing
6.01.22	FM520058	Seeger ring
6.01.23	FM290239	Support
6.01.24	FM140019	Female guide support
6.01.25	FM040009	Adjusting brake
6.01.26	FM140020	Male guide support
6.01.27	FM290131	Support
6.01.28	FM510049	Handwheel

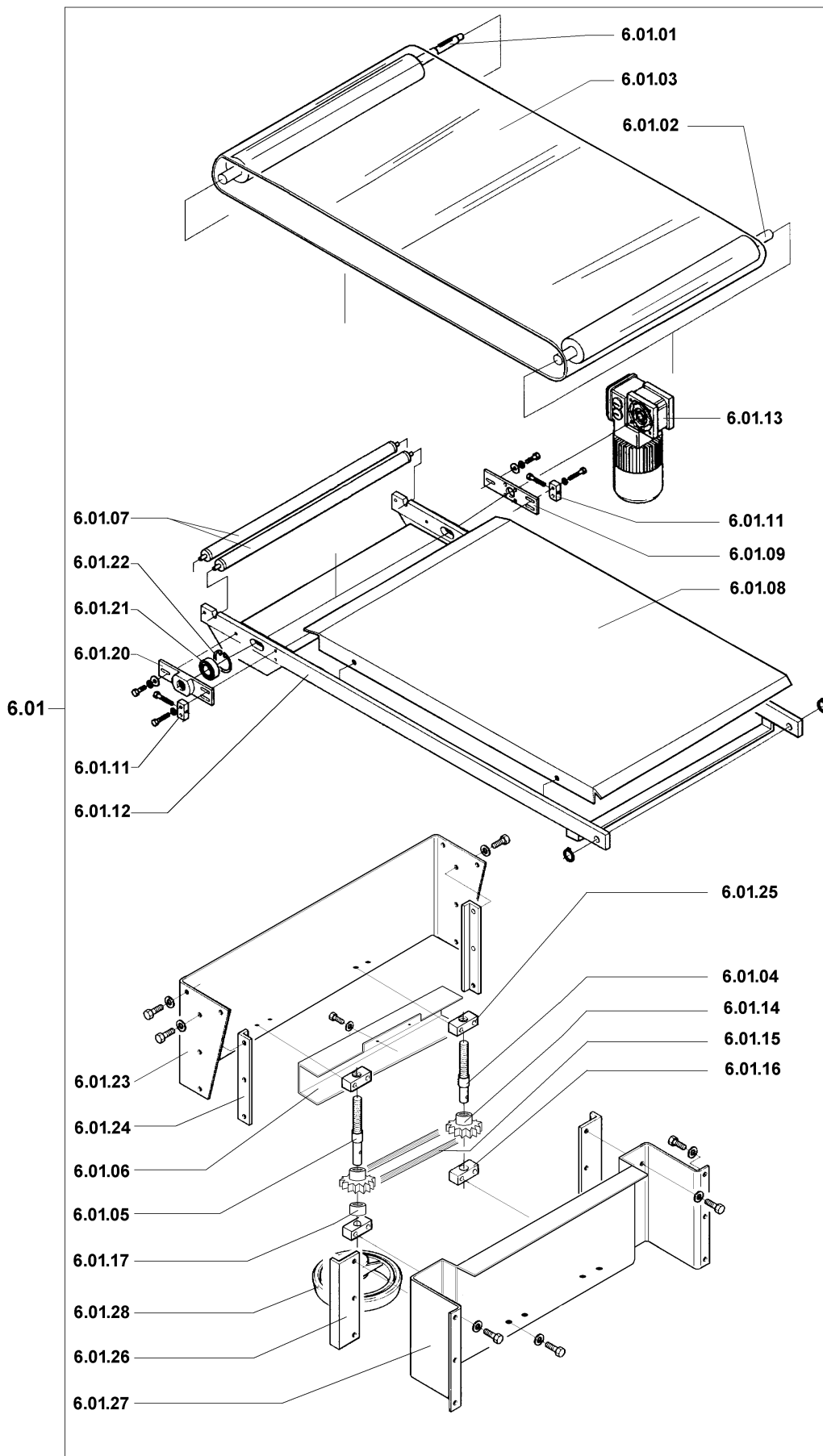

**ITEMS DESCRIPTION****SCHEME 7**

<b>Pos.</b>	<b>Code</b>	<b>Description</b>
7.01	FE260020	Fan
7.02	FM290171	Support
7.03	FM400001	Cooling system battery
7.04	S0K02005 S0K02004	Electropump kit (for 230-380-415V 50Hz) Electropump kit (for 200V 50Hz – 208/220V 60Hz – 380V 50/60Hz)
7.05	FM092001	Base plane
7.06	FM250506	Tank tube Lg.660mm
7.07	FM250554	Cooling plant tube Lg.660mm
7.08	FM250512	Cooling plant tube Lg.1300mm
7.09	FM250554	Cooling plant tube Lg.660mm
7.10	FM250508	Cooling plant tube Lg.330mm
7.11	FM160102	Cooling plant filler
7.12	FM160103	Lock nut
7.13	FM510302	Cap

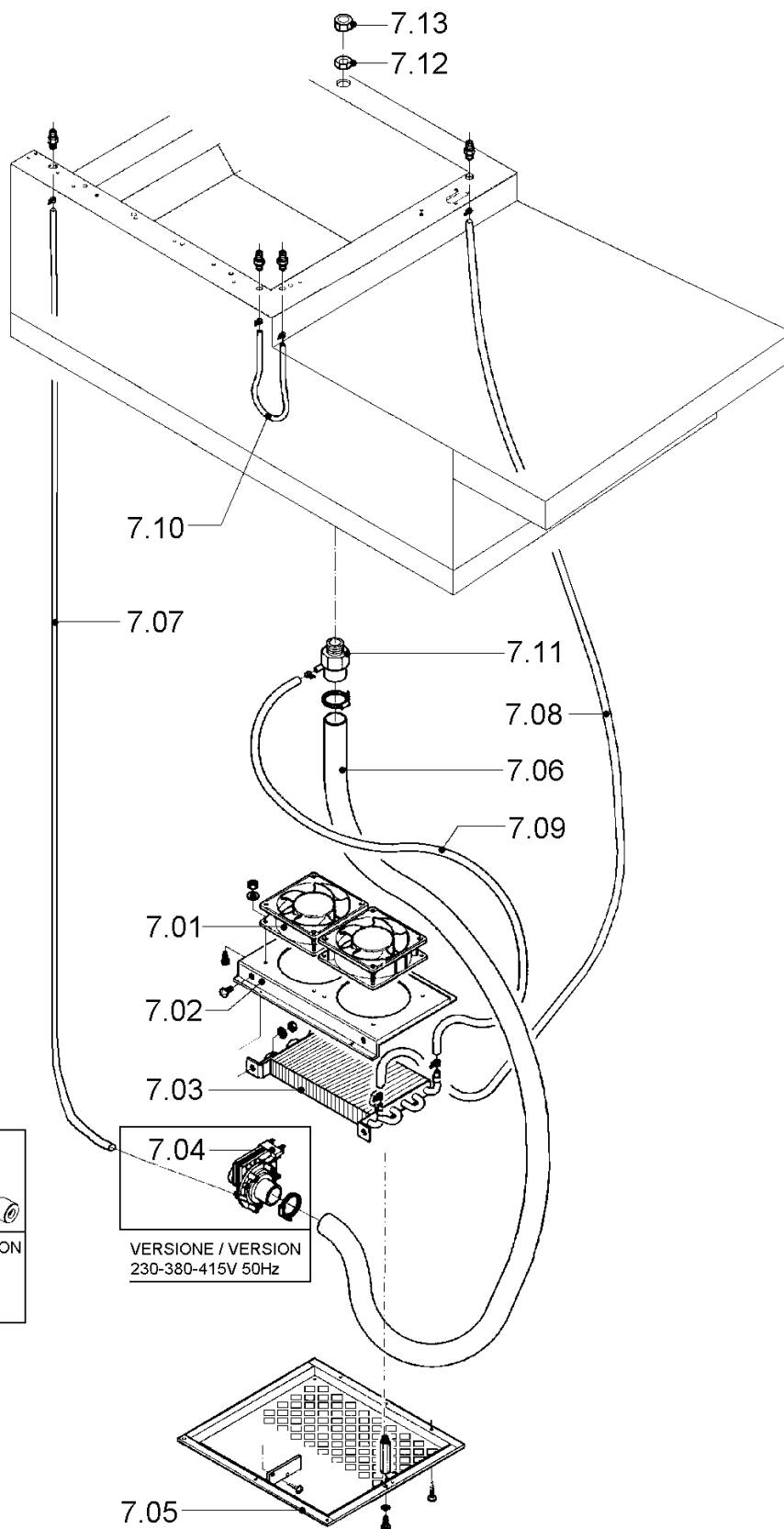

7.04

VERSIONE / VERSION  
200V 50Hz  
208/220V 60Hz  
380V 50/60Hz

7.04

VERSIONE / VERSION  
230-380-415V 50Hz

**ITEMS DESCRIPTION****SCHEME 8**

<b>Pos.</b>	<b>Code</b>	<b>Description</b>
8.01	FM300021	Frame
8.02	FM290138	Microswitch support
8.03	FE220135	Microswitch
8.03.01	FE220251	Microswitch
8.04	FM610708	NSK support
8.05	FM060015	Handle
8.06	FM160031	Spacer
8.07	FM640002	Rod end
8.08	FM060016	Connecting rod
8.09	FM760005	Reduction gear
8.10	FE245004	220-380-415V Motor
	FE245006	200-208V Motor
8.11	FM290223	Cams support
8.12	FM070024	Cam
8.12.01	FM070010	Cam
8.13	FM010012	Shaft

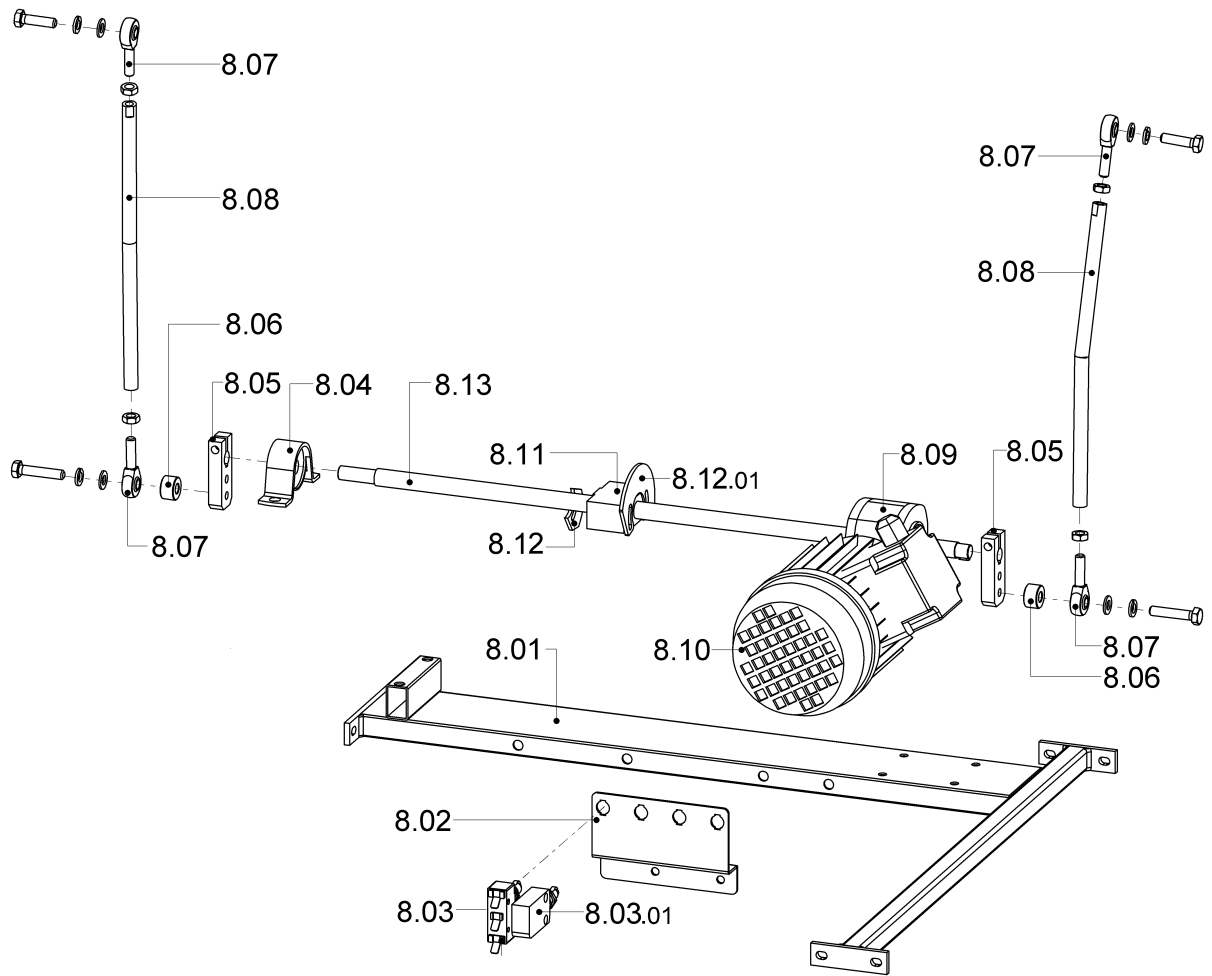

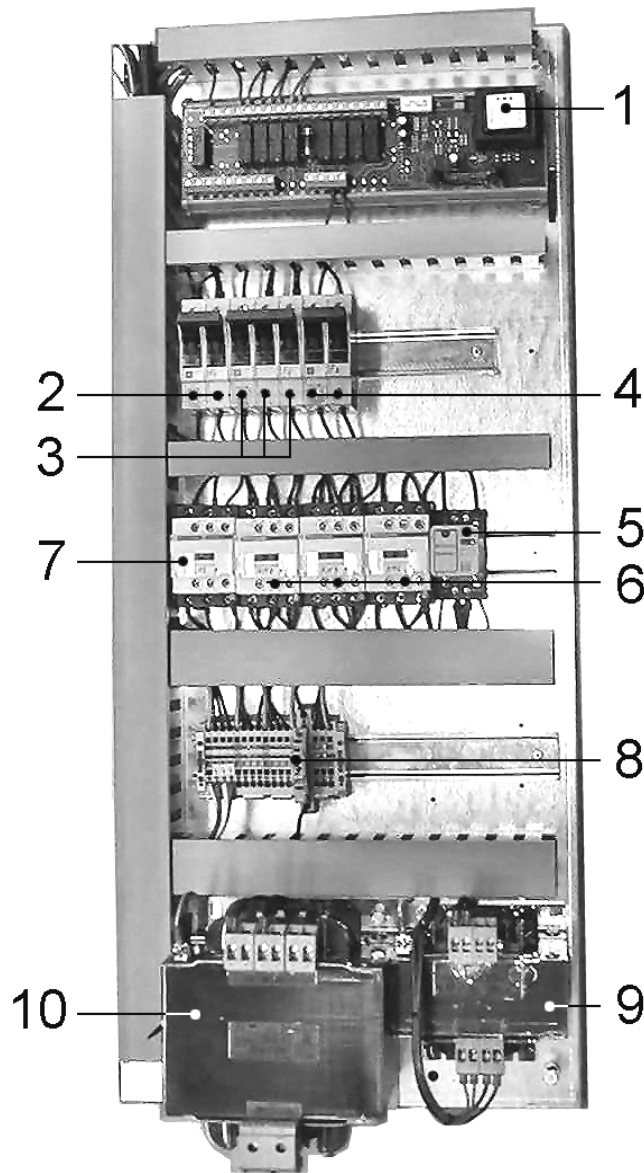

POS.	ITEMS CODE	ITEMS DESCRIPTION	Q.ty
1	FE120349	Power board	1
2	FE290456	Fuse 10A gG (380-415V)	2
	FE290407	Fuse 16A AM (200-208-220V)	
3	FE290401	Fuse 2A AM	3
4	FE290401	Fuse 2A AM (380-415V)	2
	FE290402	Fuse 4A AM (200-208-220V)	
5	FE370006	Rele 24V	1
6	FE110602	Contactor LC1-D09B7	3
7	FE110615	Contactor LC1-D18B7	1
8	FE290121	Fuse T2A	1
9	FE440026	Transformer 400VA (380-415V)	1
	FE440025	Transformer 400VA (200-208-220V)	
10	FE440628	Transformer 2500VA (380-415V)	1
	FE440627	Transformer 2500VA (200-208-220V)	