



Minipack-torre S.p.A.
Via Provinciale, 54 - 24044 Dalmine (BG) - Italy
Tel. (035) 563525
E-mail: info@minipack.it
<http://www.minipack.it>



VACUUM PACKING MACHINE

MX 5

(Machine code: **MV25IA03 / MV25IE03**)

2 FRONT BARS VERSION

Spare parts catalogue

(Valid from serial number 2444042 dated 03.2024)

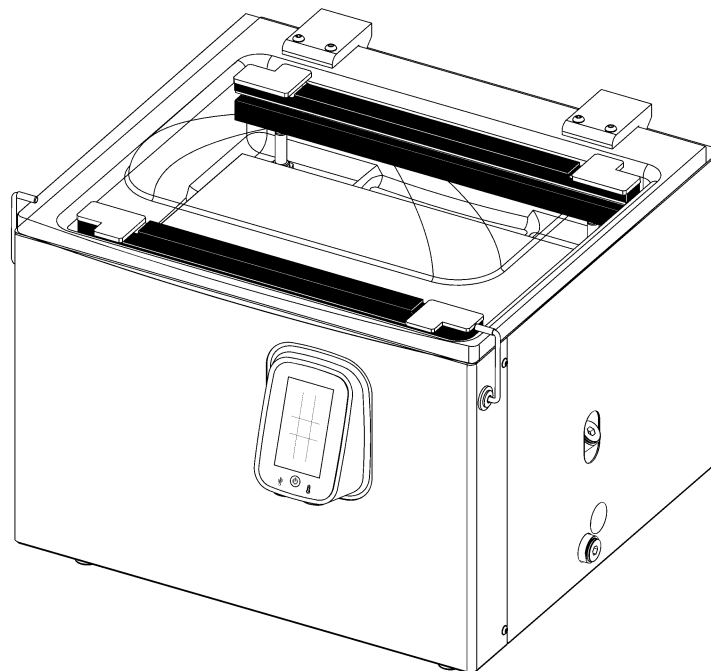

CAREFULLY READ THIS CATALOGUE BEFORE ORDERING ANY SPARE PART



DOC. N. FM112373
REV. 01
ED. 03.2024

ITEMS DESCRIPTION

Pos.	Code	Description
1	KR251011	Cover kit
1.01	-	Cover
1.02	KR991068	Silicone gasket
1.03	FM350244	Counter-bar profile
2	FM640089	Gas spring
3	FM060200	Cover lever
4	FM040565	Hinge fixing block
5	BS250010	Front sealing bar
6	FM240139	Plate
7	FM630094	Magnet
8	FM091984	Tray
9	FM510226	Support
10	P0K01443	Reed sensor pre-assembly
11	FM750208	L union f.f. G 1/2"
12	FM750209	Rubber holder 1/2" x Ø20
13	FM750274	m-f 1/2" - 1/4" reducer
14	FM750257	Gasket 1/4"
15	FM160788	Suction cap
16	ME450003-1	Membrane group
17	FM650103	Gasket OR 4106
30	FM291706-1	Rear panel
31	FM096825-1	Body
32	FM291707-1	Front
33	FM510222	Foot
34	P0K01471	Display+board
35	P0K01530-1	Cover hook
36	FM730062	Vacuum pump 20mc 230V 1Ph
	FM730063	Vacuum pump 20mc 120V 1Ph
37	FM750229	Tapered nipple G 1/2"
38	FM750317	T- union 1/2"
39	FM750229	Tapered nipple G 1/2"
40	FM750208	L union f.f. G 1/2"
41	FM750209	Rubber holder 1/2" x Ø20
42	FM750406	m.f. 3/4" - 1/2" reducer
43	FE140002	Air return solenoid valve
44	FM750299	Silencer 3/4"
45	FE140010	Sealing solenoid valve
46	FM750220	Threaded sleeve
50	FE120431	Main board
51	FE440828	Transformer 700VA 230-29+29V
	FE440829	Transformer 700VA 120-29+29V
52	FE110508	Contactora (230V)
	FE110628	Contactora (120V)
53	FE290405	Fuse 10.3x38 AM 10A (230V)
	FE290708	Fuse 10.3x38 FNQ 20A (120V)
54	FE120013	Thermal 7A (230V only)
55	FE120018	Thermal 25A (230V)
	FE120012	Thermal 20A (120V)
56	FE120018	Thermal 25A (230V)
	FE120012	Thermal 20A (120V)
57	FE080001	Main switch 0-1 3P 20A

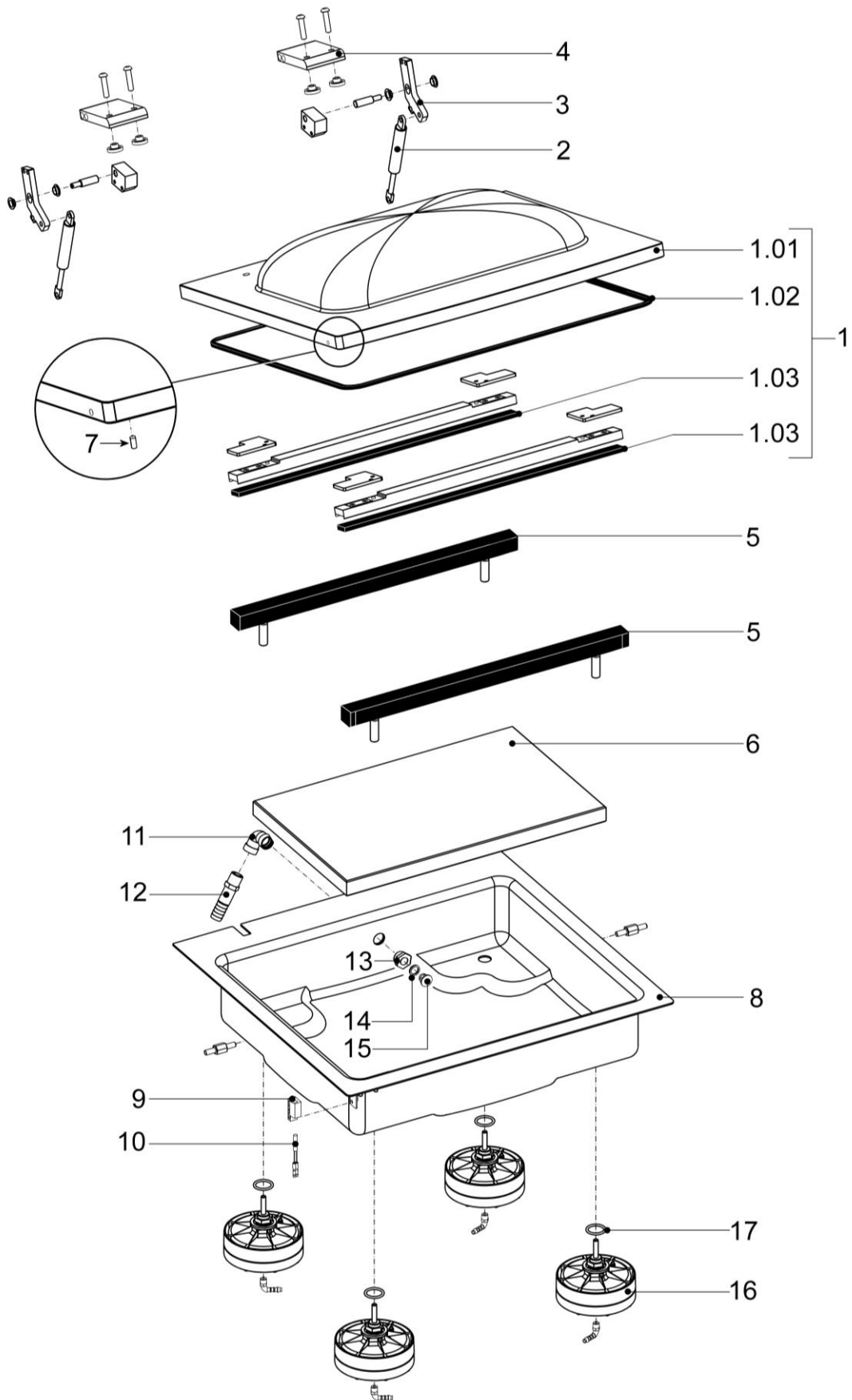

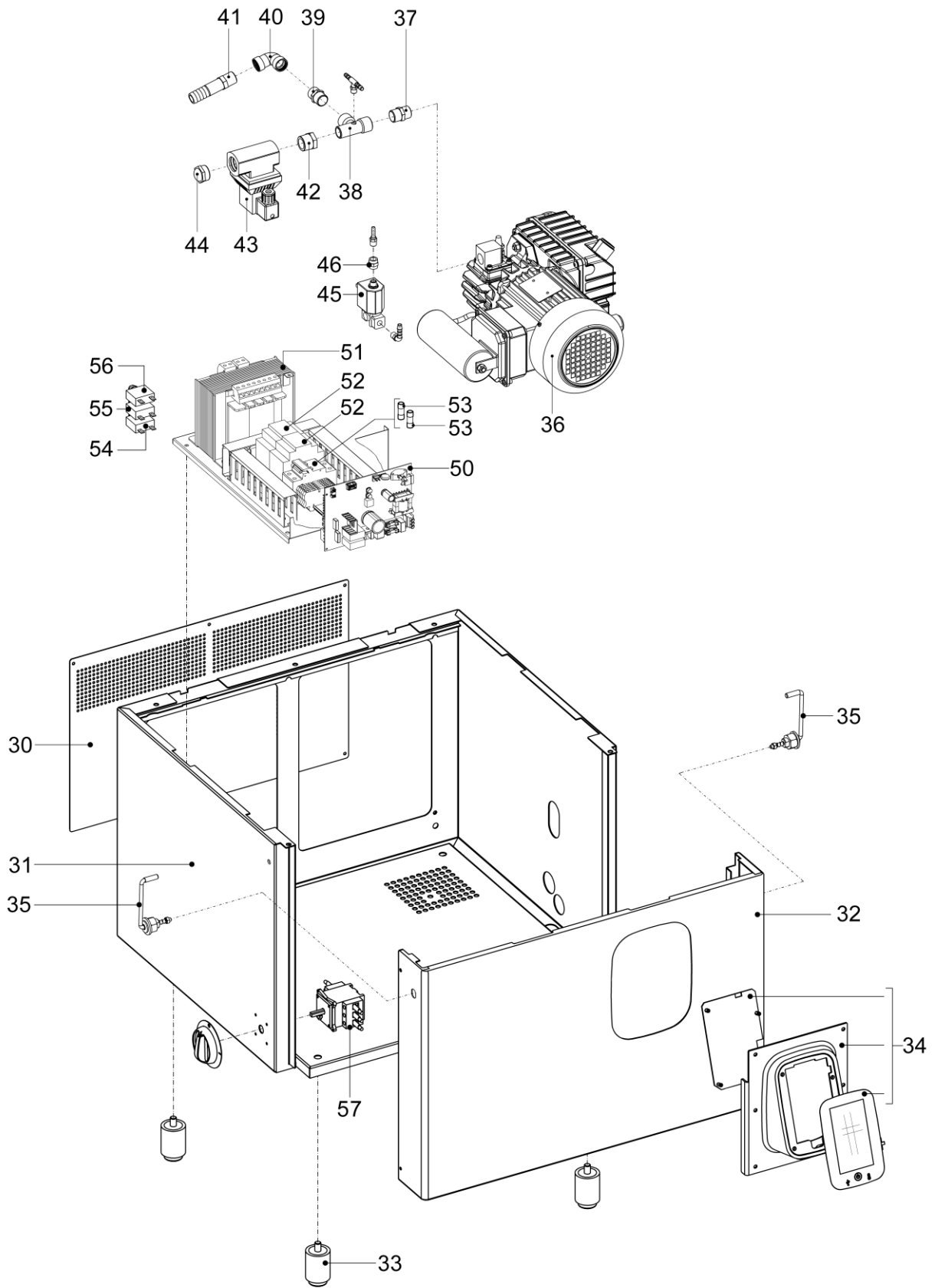

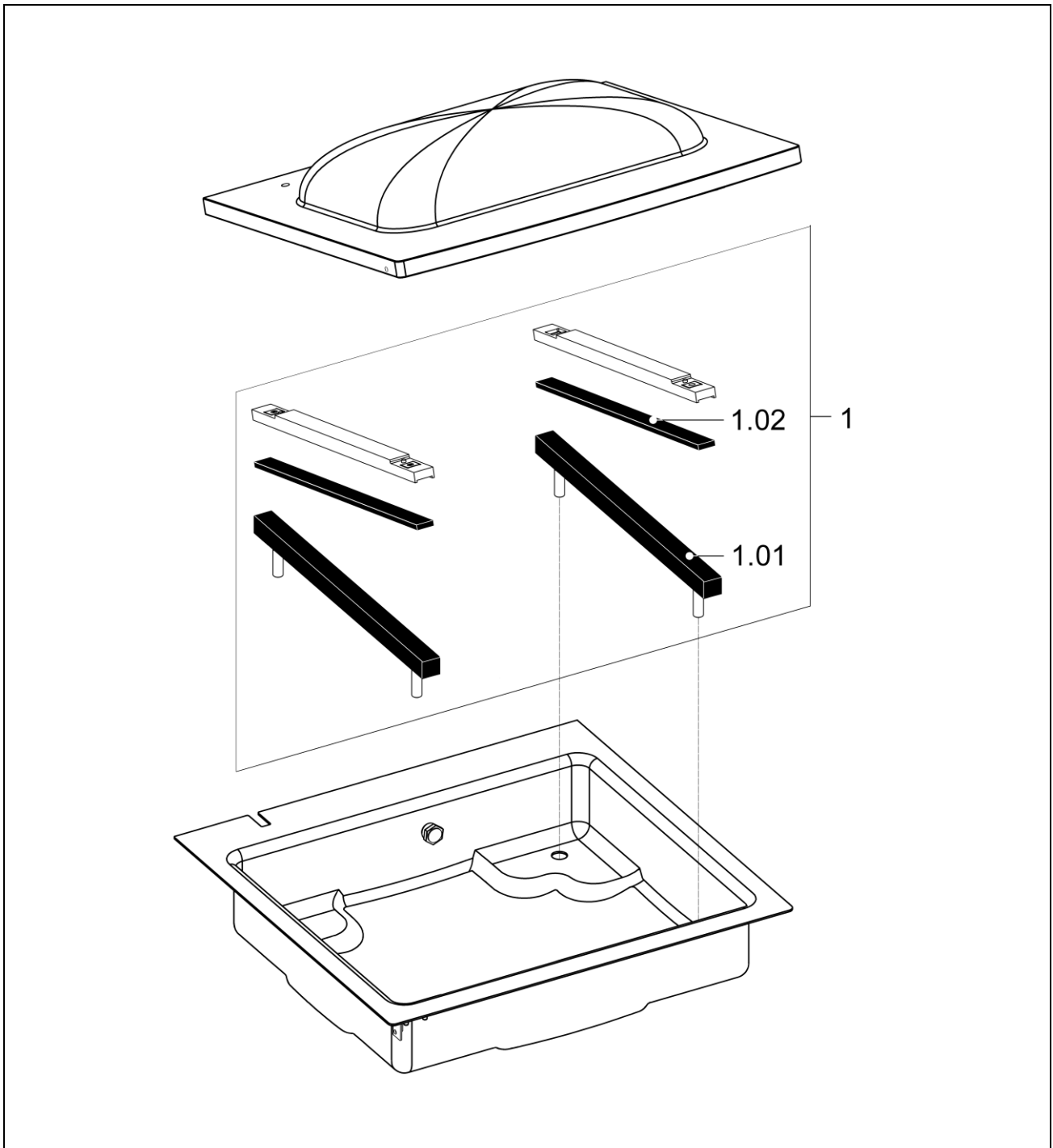

Pos.	Code	Description
1	KR251001	Kit 2 side bars
1.01	BS250011	Side sealing bar
1.02	FM350245	Counter-bar profile